

| ITEM NO. | PART NUMBER | DESCRIPTION | QTY. |
|----------|-------------|--------------|------|
| 1 | AF-GP-01 | HOOK, MLI QT | 2 |
| 2 | AF-GP-02 | LUG, MLI QT | 2 |

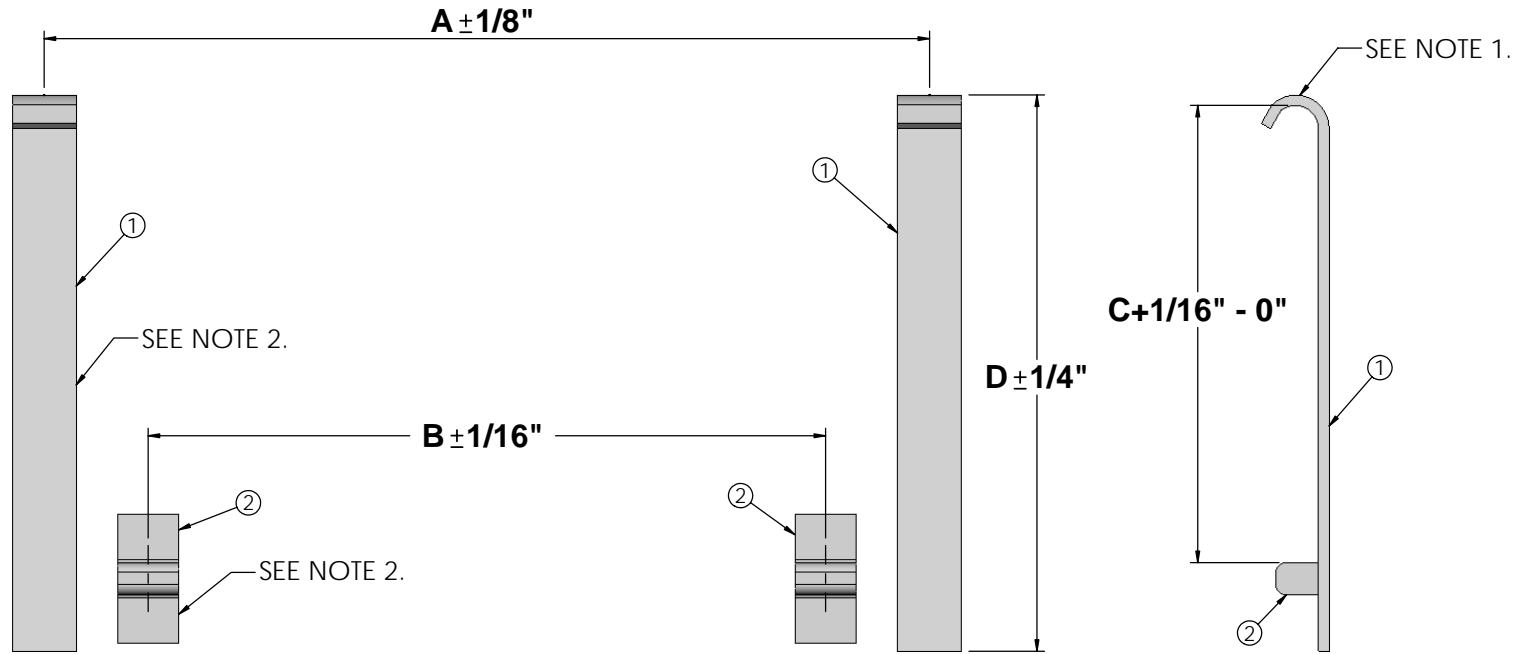

| LOADER | Dimension "A" (Hook Center/Center) | Dimension "B" (Lug Center/Center) | Dimension "C" (Lug Position) | Dimension "D" (Hook Size) |
|---------------------------------|---------------------------------------|--------------------------------------|---------------------------------|------------------------------|
| G15, G20 | 41-1/2" | 32-1/4" | 14-9/16" | 20" |
| Model 12, P-12, R-12 | 38-3/4" | 29-1/2" | 21-7/16" | 26" |
| GL25, GP25, PL-2, PL-2JR, PL-2X | 41-1/2" | 31-3/4" | 21-7/16" | 26" |
| GL30, GP30, PL-3, PL-4, PL-5 | 44-1/2" | 34-5/8" | 21-7/16" | 26" |
| PL-1 | 51" | 41-1/4" | 21-7/16" | 26" |
| Super | 42-3/4" | 33-1/4" | 21-7/16" | 26" |

NOTES:

1. TOP OF HOOK MUST BE SUPPORTED TO KEEP IT FROM FLEXING.
2. WELDS MUST BE CONTINUOUS 1/4" FILLET AROUND THE LUGS AND 3/16" AROUND THE HOOKS.



SCHEMATIC

Miller QT Dimensions

DWG. NO. MQT-2005

WEIGHT:

DATE Monday, August 15, 2005 1:21:19 PM

SHEET 1 OF 1