



OWNER'S MANUAL



P-12 LOADER **PARTS and INSTRUCTIONS**

1242 ARIZONA AVE.
LARCHWOOD, IA 51241
1-800-570-8205



DANGER



TO PREVENT POSSIBLE ROLLOVER, OBSERVE THE FOLLOWING SAFETY PRECAUTIONS

- ◆ Carry loads as low as possible
- ◆ Drive tractor slowly when turning, operating on hills or inclines, or traversing uneven ground
- ◆ Raise load to full height *only* when tractor is on even ground and front wheels are straight ahead

TO PREVENT POSSIBLE PERSONAL INJURY, OBSERVE THE FOLLOWING SAFETY PRECAUTIONS

- ◆ Never walk or work under a raised loader that is not firmly supported
- ◆ Always relieve the hydraulic system to zero pressure before performing repairs on any component of the loader's hydraulic system

TABLE OF CONTENTS

- Maintenance Information
- Install Loader Mountings
- Mounting Loader on Tractor
- Dismounting Loader
- Quick-attach Instructions
- Parts Schematics
- Warranty

SERIAL No. of Loader Purchased _____

Date Purchased _____

MAINTENANCE

PERIODICALLY...

1. GREASE THE LOADER PINS. The frequency that they should be greased depends on how often the loader is used, what kind of materials are being handled and the severity of the usage. A good rule of thumb is to simply keep the pin sleeve full of grease. In some operations, this requires that the pins be checked every day. Allowing a pin to become dry leads to problems that will not be covered by the warranty. Please read the warranty in the back of this manual.

COMPOSITE BEARINGS. The P-12 loader you have purchased has composite bearings in two locations (see Figure 1 below). These bearings have a self-lubricating feature that will last the life of the loader. They do not require grease. They are heavy-duty bearings specifically designed for high impact loads, high and low temperatures, and dirty environments.

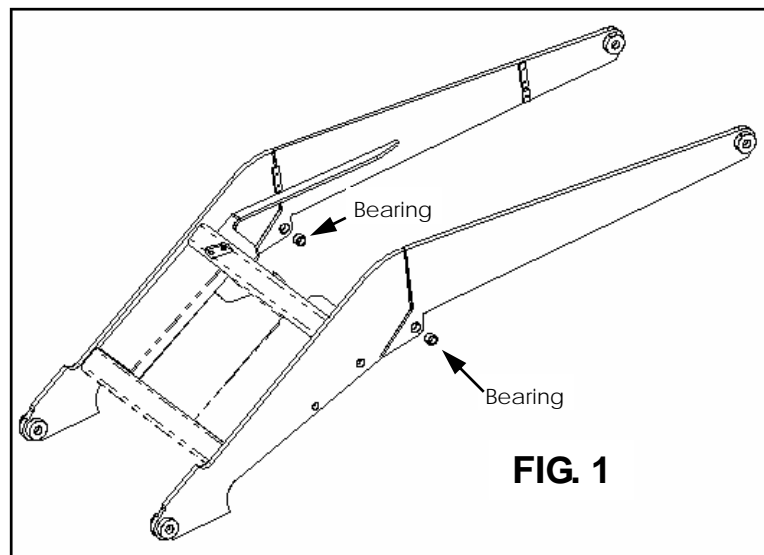

2. GREASE THE QUICK-ATTACH DROP PINS AND SLIDING LATCHES. These parts come greased from the factory. They should be greased periodically to ensure that they will drop through the attachment lugs easily.

3. CHECK THAT ALL MOUNTING BOLTS ARE TIGHT. Even though lock-washers are used on all mounting hardware, the nuts and bolts can become loose. If the mountings become loose and are allowed to move around, high stresses can be put on the mounts and loader.

INSTALL LOADER MOUNTINGS

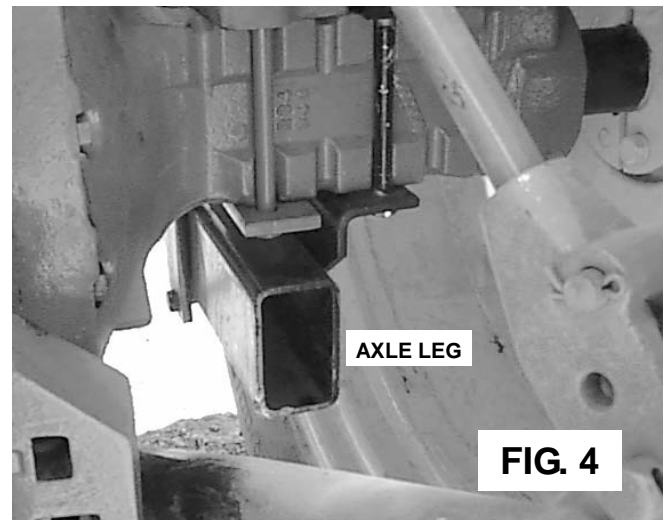
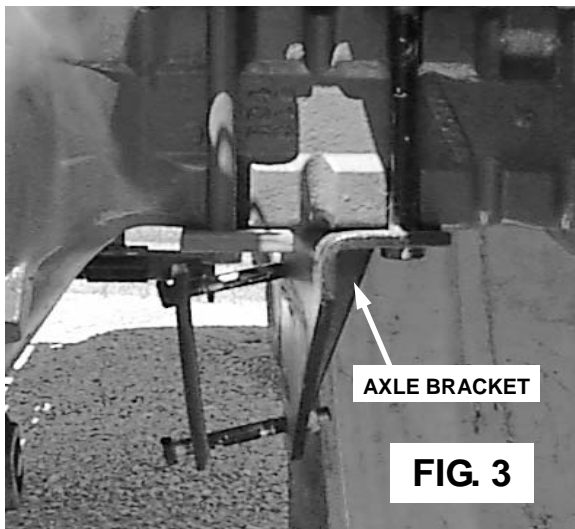
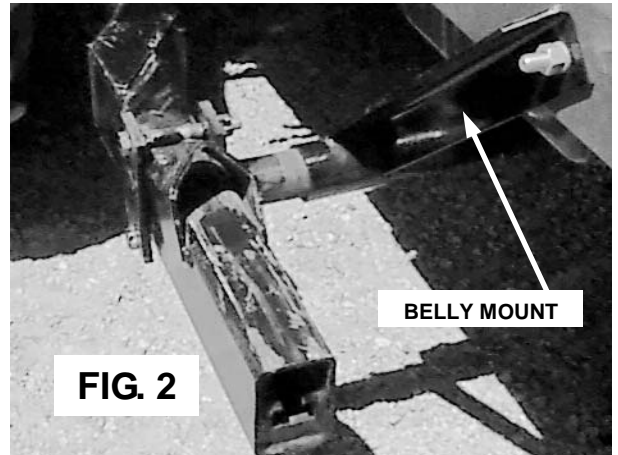

STEP 1 Attach the front mount to the tractor. Any weight brackets, tool boxes or other items that will interfere with the loader must be removed at this time. Tighten front mount bolts securely. See Fig. 1

STEP 2 Attach the belly mount to the tractor. Belly mount styles vary but usually clamp around the axle leg (as shown in Figure 2, the axle leg shown in this figure is not installed until step four). Install the bolts for the belly mount but do not tighten them.

STEP 3 Attach the axle brackets to the tractor. The brackets are usually clamped to the axle housing as shown in Figure 3, but can also bolt directly to the tractor cab mount. Tighten the bracket bolts securely. The normal inside-to-inside spacing of the axle legs is 36 inches. For a tractor set up for 30-inch row crops, offset axle legs are available which reduce this spacing to 32 inches.

STEP 4 Slide the rear end of the 3 x 5 axle legs into axle brackets and mount the front of the axle legs to the belly mount (See Figures 2 & 4). Adjust the axle leg so that the front of the leg is approximately 54 inches behind the channel opening of the front mount. Install and snug the bolts used to secure the legs in place but do not tighten them.

CONTINUED ON NEXT PAGE

INSTALL LOADER MOUNTINGS

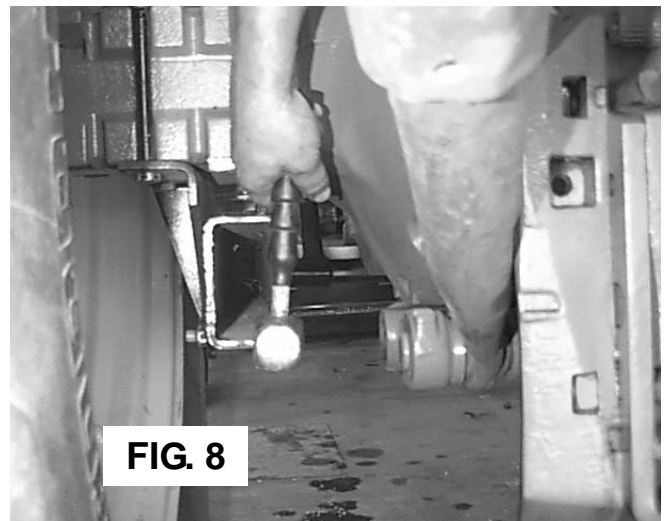
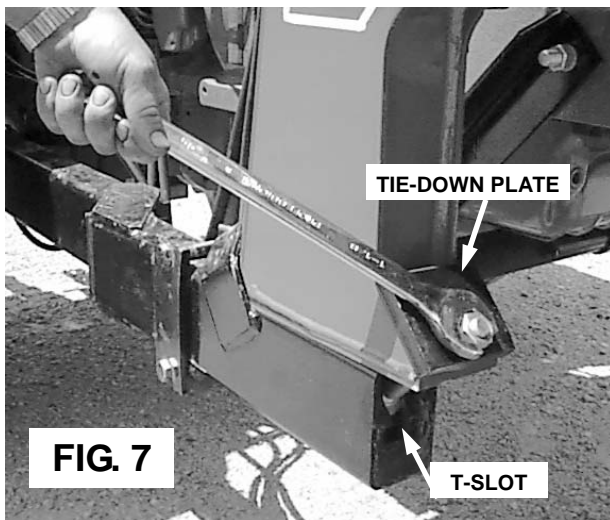
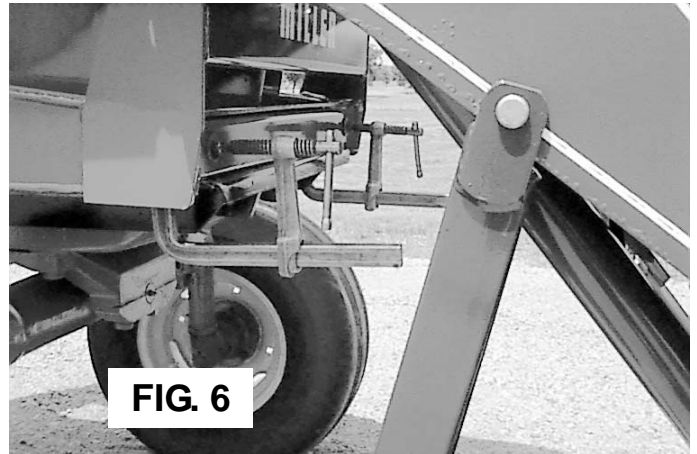
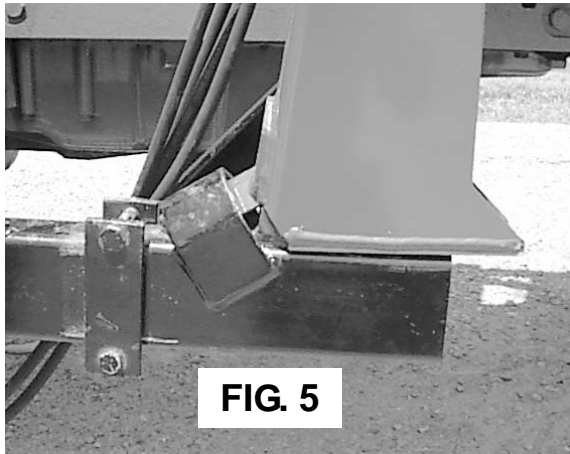

STEP 5 Place the loader into position so that it is resting on the axle legs as shown in Figure 5. The front tube of the loader should also slide into the channel of the front mount. It is very important when installing the loader mounts for the first time that loader be positioned as deeply as possible into the front mount. This can be accomplished with two large C-clamps (see Fig. 6).

STEP 6 Insert the head of the tie-down bolt into the T-slot in the front of the axle leg and slip the tie-down plate over the end of the bolts. Install the lock washer and nut, but do not tighten completely (see Fig. 7).

STEP 7 Using a large hammer, tap the axle legs forward (see Fig. 8). Tighten the tie-down bolts installed in Step 6. Continue to tap and tighten until the “foot” of the loader frame is completely seated into the strap on the axle leg.

**THE MOUNTINGS ARE NOW IN THE PROPER POSITION.
TIGHTEN ALL MOUNTING BOLTS SECURELY**

MOUNTING LOADER

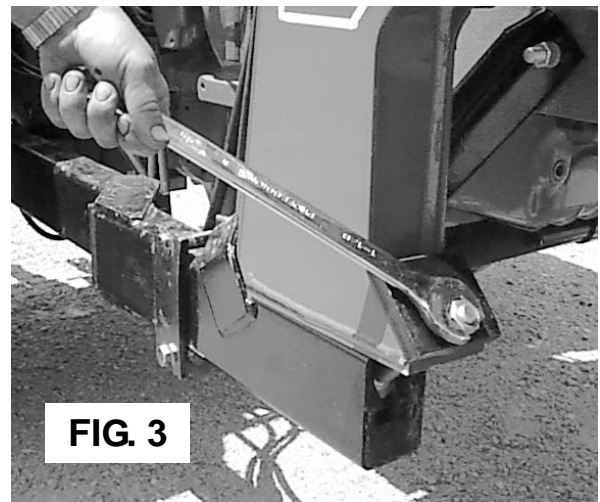
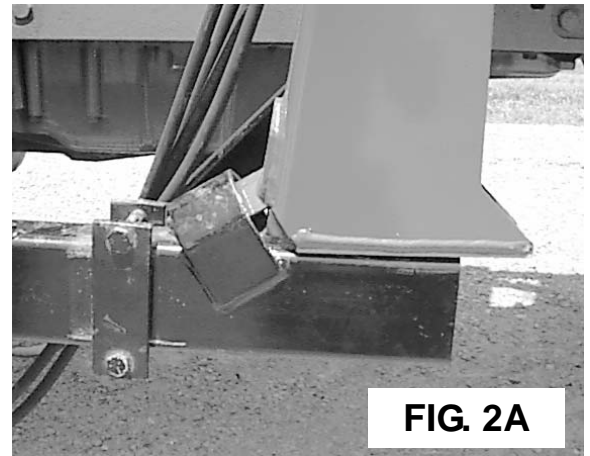

STEP 1 Approach the loader as shown in Figure 1 and connect the hydraulic hoses.

STEP 2 Retract the bucket cylinders to align the loader with the mountings on the tractor. The foot of the loader should rest on the axle leg (see Figure 2A) and the front tube of the loader should seat into the front mount channel (see Figure 2B).

STEP 3 Insert the head of the tie-down bolt into the T-slot in the front of the axle leg, slide the tie-down plate over the end of the bolt and tighten using 3/4 nut and lock washer as shown in Fig. 3.

STEP 4 Raise the loader off of the stand legs so that they can be removed.

STEP 5 Remove the stand legs from the front of the loader and store them.

DISMOUNTING LOADER

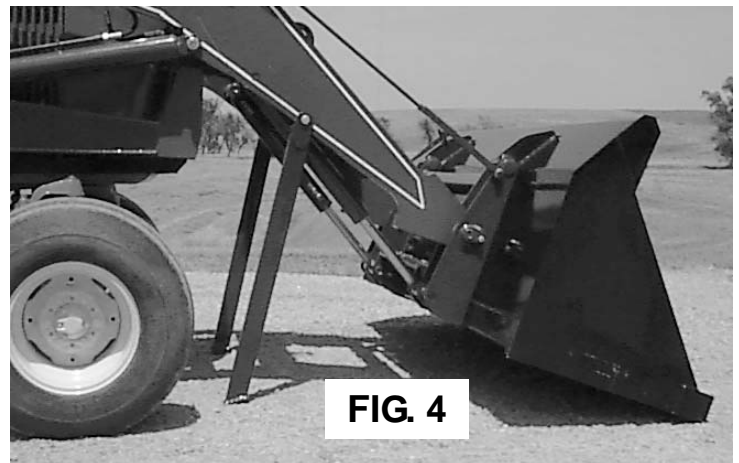
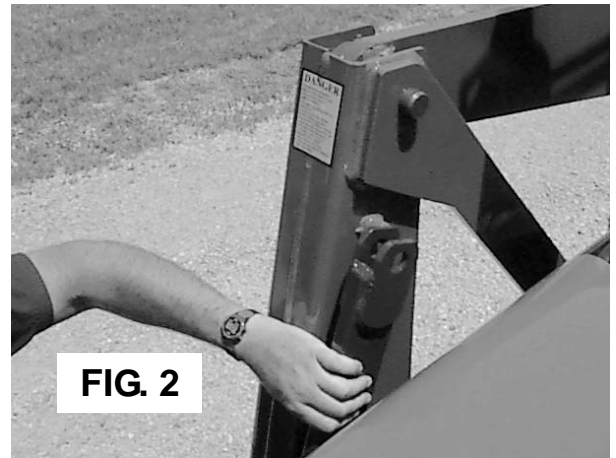

STEP 1 *DRIVE THE TRACTOR TO FIRM, EVEN GROUND* and place the loader in the position shown in Fig 1.

STEP 2 Remove the stand legs from the upright frame of the loader as shown in Figure 2.

STEP 3 Using the supplied 1-inch pins, hang the stand legs from the mainframe of the loader as shown in Fig. 3.

STEP 4 Gently lower the loader until the stand legs barely touch the ground. Please note that the stand legs are not designed to withstand the down-force that can be created with the lift cylinders, they are designed to support the weight of the loader only. Use the bucket cylinders to rotate the bucket down until the cutting edge is resting on the ground as shown in Figure 4.

CONTINUED ON NEXT PAGE

DISMOUNTING LOADER

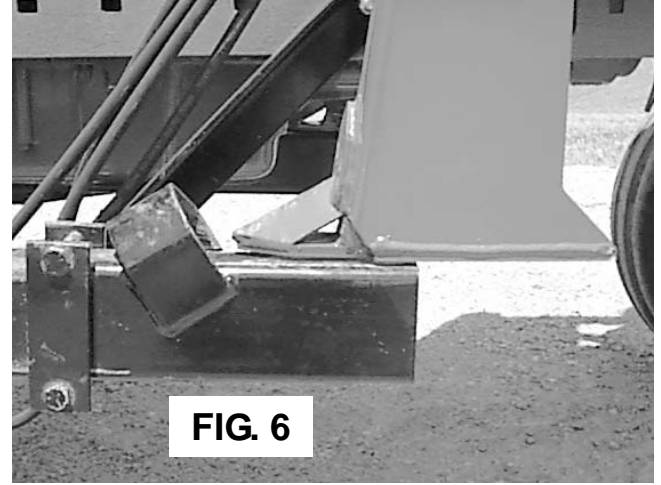
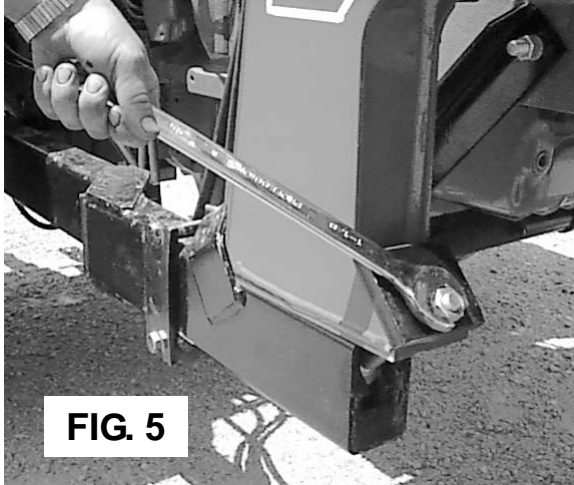

STEP 5 Remove the tie-down bolts and tie-down plates that clamp the loader to the axle legs as shown in Fig. 5.

STEP 6 Back up the tractor slowly until the “foot” of the loader is clear of the strap on the axle leg as shown in Fig. 6

STEP 7 Use the bucket cylinders to flatten the bucket as shown in Figure 7. The loader should pivot on the stand legs and come to rest in a stored position.

STEP 8 Disconnect the hydraulic hoses and back the tractor away from the loader.

QUICK-ATTACH INSTRUCTIONS

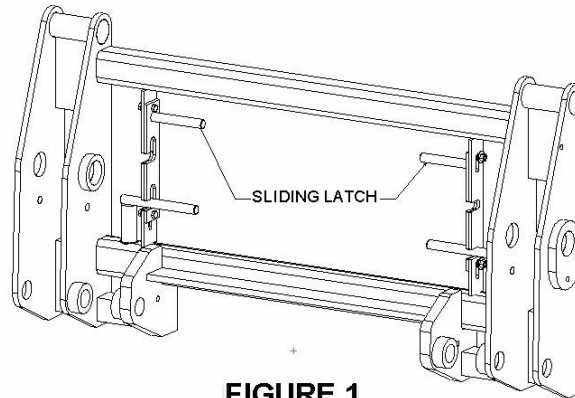

FIGURE 1.

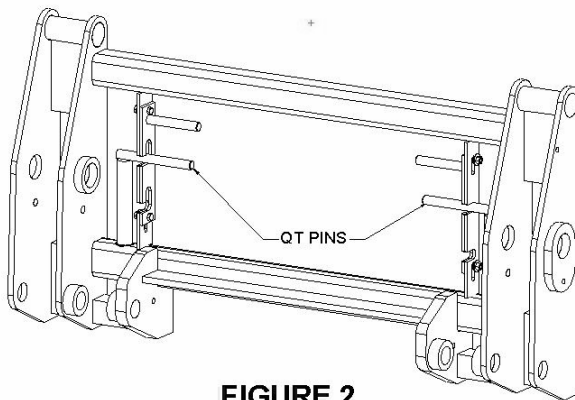

FIGURE 2.

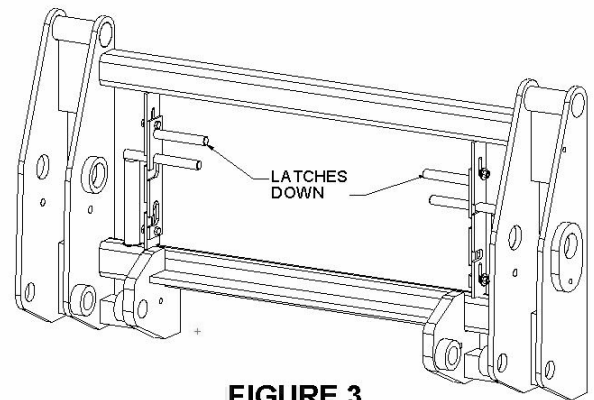

FIGURE 3.

UNCOUPLING

1. Raise sliding latches as shown in Figure 1.
2. Rotate QT pins out of the lower notches, raise, and then rotate them into the upper notches of the sliding latches as shown in Figure 2.
3. Slide the sliding latches down as shown in Figure 3. This secures the QT pins in the “up” position so they do not interfere when hooking up to the next attachment.

COUPLING

1. Approach and hook onto the attachment with QT pins secured in the “up” position as shown in Figure 3.
2. When the QT frame is flat against the attachment, raise the sliding latches as shown in Figure 2.
3. Rotate QT pins out of the upper notches, lower, and then rotate them into the lower notches on the sliding latches as shown in Figure 1. **NOTE:** If the QT pins do not easily slide thru the lug on the attachment, do not force them. Simply rotate the attachment back and forth slowly with the bucket cylinders of the loader and the QT pins should fall into place. Periodically grease the QT pins and sliding latches.
4. Secure the QT pins in the “down” position by sliding the latches down.

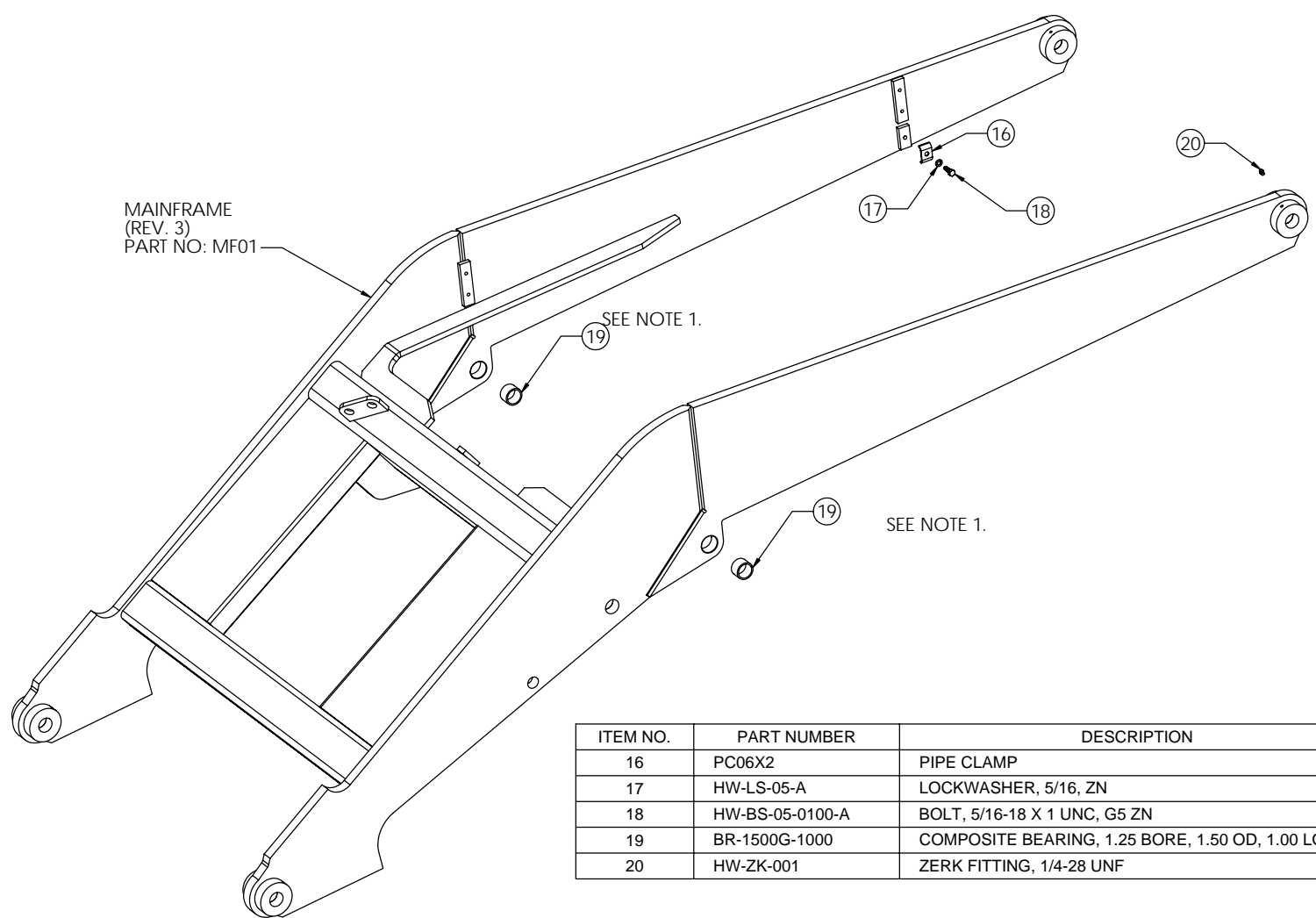

MAINFRAME
(REV. 3)
PART NO: MF01

SEE NOTE 1.

SEE NOTE 1.

ITEM NO.	PART NUMBER	DESCRIPTION	Rev. 3 (Schematic)/QTY.
16	PC06X2	PIPE CLAMP	1
17	HW-LS-05-A	LOCKWASHER, 5/16, ZN	1
18	HW-BS-05-0100-A	BOLT, 5/16-18 X 1 UNC, G5 ZN	1
19	BR-1500G-1000	COMPOSITE BEARING, 1.25 BORE, 1.50 OD, 1.00 LONG	2
20	HW-ZK-001	ZERK FITTING, 1/4-28 UNF	1

NOTES:
1. THE COMPOSITE BEARING USED AT THIS PIVOT POINT HAS A SELF-LUBRICATING FEATURE THAT SHOULD LAST MANY YEARS



SCHEMATIC

MAINFRAME, P-12

DWG. NO. MF2003

WEIGHT:
DATE Thursday, May 04, 2000 9:10:44 AM
SHEET 1 OF 1

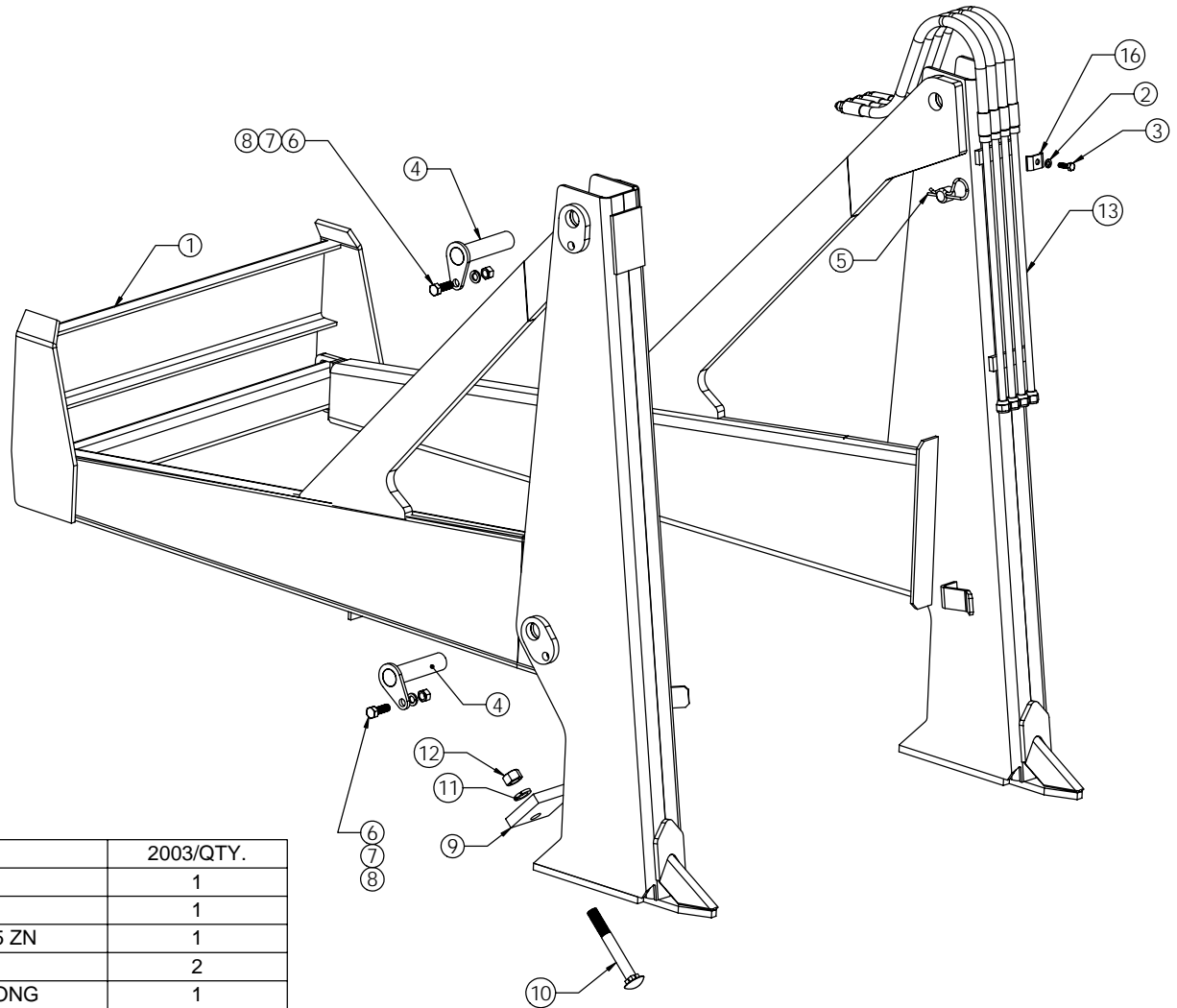

ITEM NO.	PART NUMBER	DESCRIPTION	2003/QTY.
1	UR01	UPRIGHT FRAME, P-12	1
2	HW-LS-05-A	LOCKWASHER, 5/16, ZN	1
3	HW-BS-05-0100-A	BOLT, 5/16-18 X 1 UNC, G5 ZN	1
4	PN-05500-A10	PIN, 5.500 X 1.25, W/RTNR	2
5	PIN1-018	HAIRPIN COTTER, 3-3/4 LONG	1
6	HW-BS-08-0150-A	BOLT, 1/2-13 X 1 1/2 UNC, G5 ZN	2
7	HW-LS-08-A	LOCKWASHER, 1/2, MED, ZN	2
8	HW-NS-08-A	NUT, 1/2-13 UNC, ZN	2
9	UR01-20	TIE DOWN PLATE, P-12	1
10	HW-BS-12-0600-A	BOLT, 3/4-10 X 6 UNC, G5, CGE, ZN	1
11	HW-LS-12-A	LOCKWASHER, 3/4, MED, ZN	1
12	HW-NS-12-A	NUT, 3/4-10 UNC, ZN	1
13	HS01-01	UPRIGHT JOINT HOSE	4
16	PC06X2	PIPE CLAMP	1



SCHEMATIC

P-12 UPRIGHT FRAME

DWG. NO. UR2003

WEIGHT:
DATE Thursday, May 17, 2001 8:51:06 AM
SHEET 1 OF 1

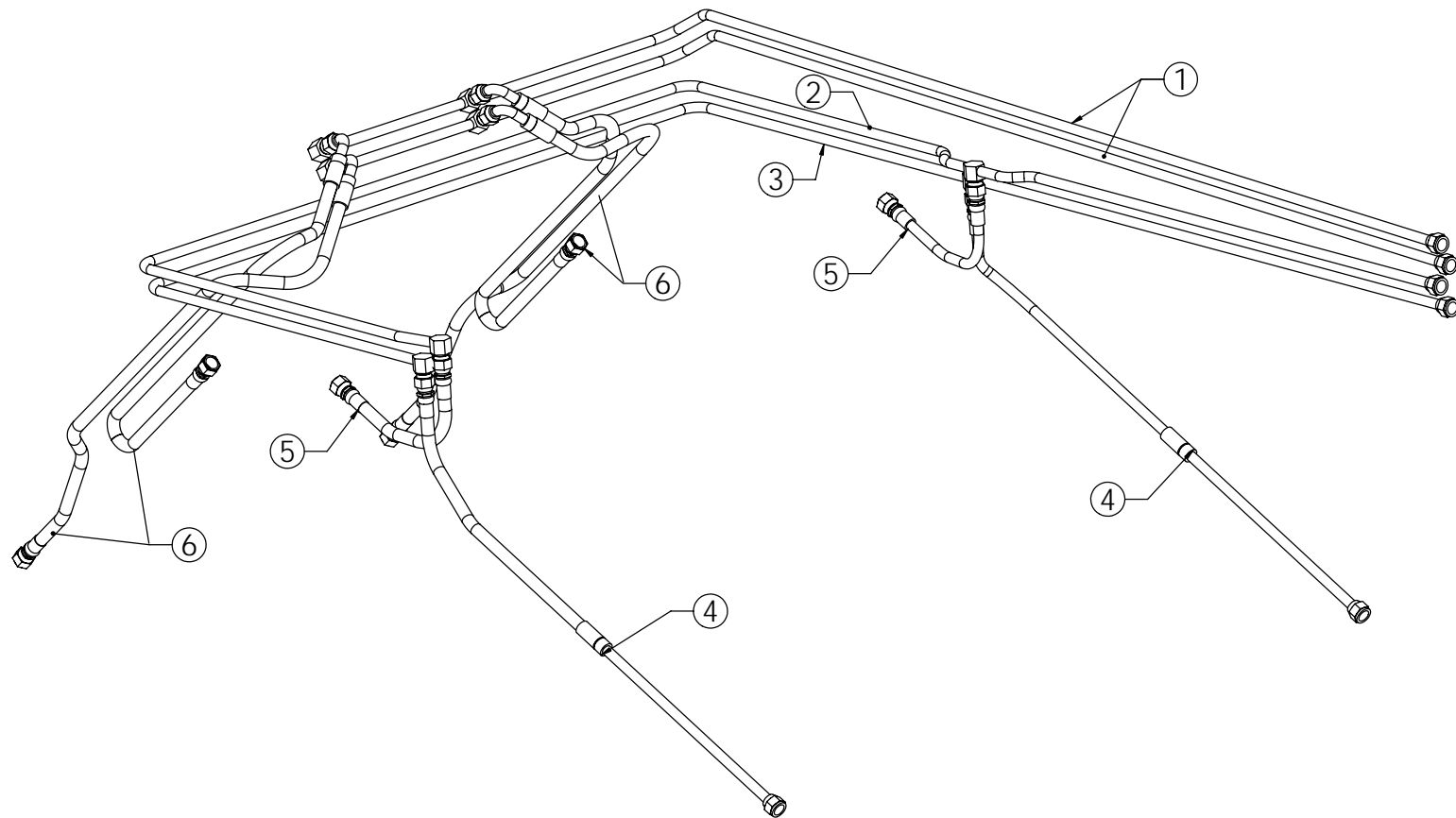

ITEM	QTY.	PART NO.	DESCRIPTION
1	2	HP01-BKP	BUCKET SUPPLY PIPE, P-12
2	1	HP01-MTP	LIFT SUPPLY PIPE (TOP), P-12
3	1	HP01-MMP	LIFT SUPPLY PIPE (BTM), P-12
4	2	HS01-LR	LIFT HOSE (RETRACT), P-12
5	2	HS01-LE	LIFT HOSE (EXTEND), P-12
6	2	HS01-B	BUCKET HOSE, P-12



SCHEMATIC

HYDRAULIC PIPING / HOSES

DWG. NO. HS2003

WEIGHT:

DATE Tuesday, December 17, 2002 2:08:50 PM

SHEET 1 of 1

ITEM NO.	PART NUMBER	DESCRIPTION	QTY.
1	QT01-W	QT, P-12 WELDED FRAME	1
2	QT02-14	RETAINING PIN ASSEMBLY, QT	2
3	QT02-01L	SLIDING LATCH ASSY, QT, LH	1
4	QT02-01R	SLIDING LATCH ASSY, QT, RH	1
5	PN-06000-A10	PIN, 6.000 X 1.25, W/RTNR	2
6	HW-BS-08-0200-A	BOLT, 1/2-13 X 2 UNC, G5 ZN	2
7	HW-LS-08-A	LOCKWASHER, 1/2, MED, ZN	2
8	HW-NS-08-A	NUT, 1/2-13 UNC, ZN	2

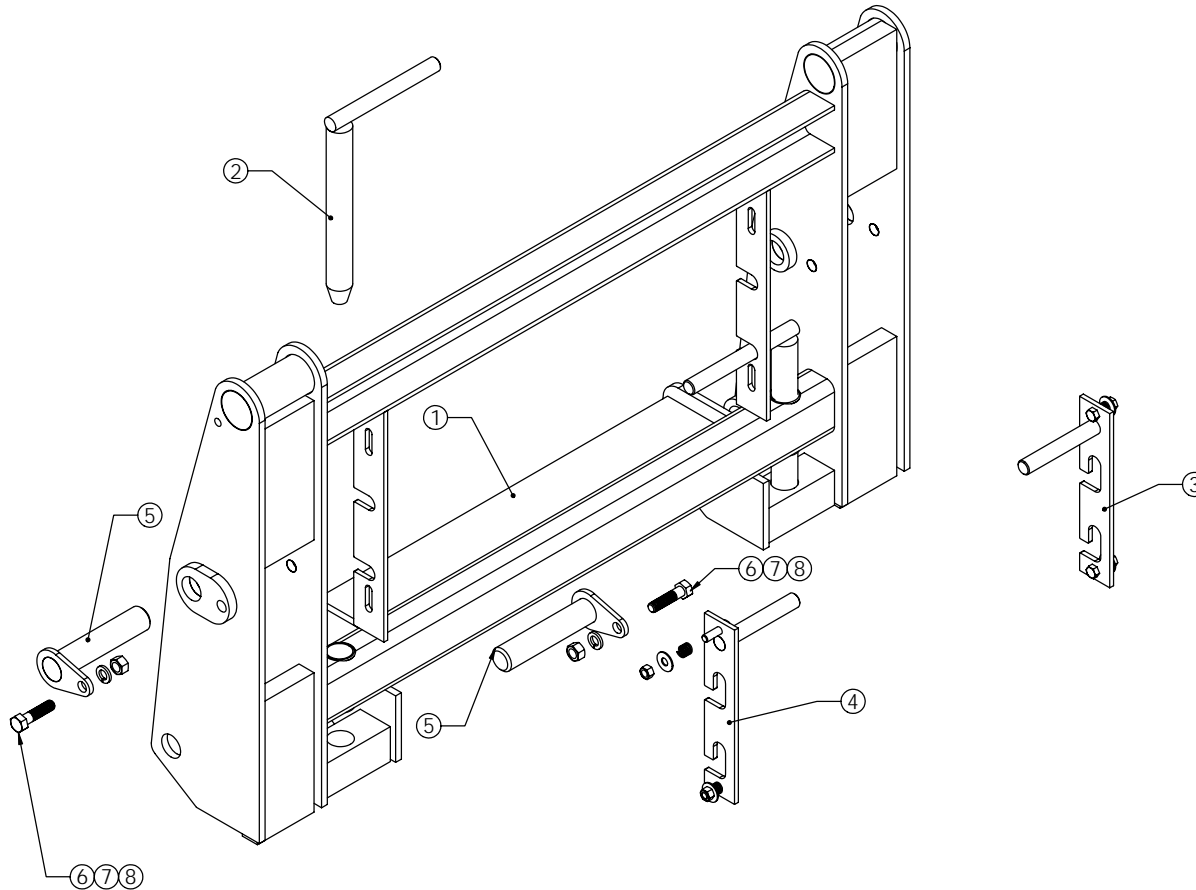

NOTES:
 1. ITEMS 5, 6, 7, AND 8 ARE SOLD SEPARATELY FROM QUICK ATTACH ASSEMBLY.

	SCHEMATIC	
	QUICK ATTACH FRAME ASSEMBLY	
DWG. NO. QT		
WEIGHT:	DATE Thursday, May 04, 2000 9:10:44 AM	SHEET 1 OF 1

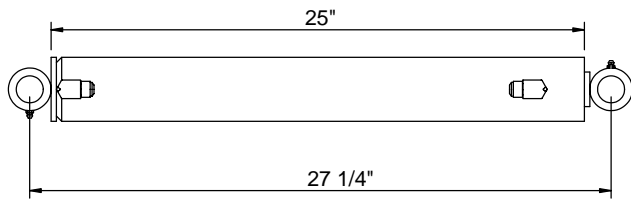

ITEM NO.	PART NUMBER	DESCRIPTION	QTY.
1	CY-001-D	ROD ASSY, P-12 BUCKET	1
2	CP-PS-2516-U	PISTON, 2516 U-CUP	1
3	CP-GL-2516-S	GLAND, 2516 SHORT-TAIL	1
4	CY-001-LJT	TUBE ASSY, P-12 BUCKET (JIC) LEFT	1
5	HW-WS-12-A	WASHER, 3/4, SAE, PLAIN	1
6	HW-NS-12-E	NUT, 3/4-16 UNF, GRC, TL	1
7	CP-KT-2516-U	P-KIT, 2.500 X 1.625 UC	1

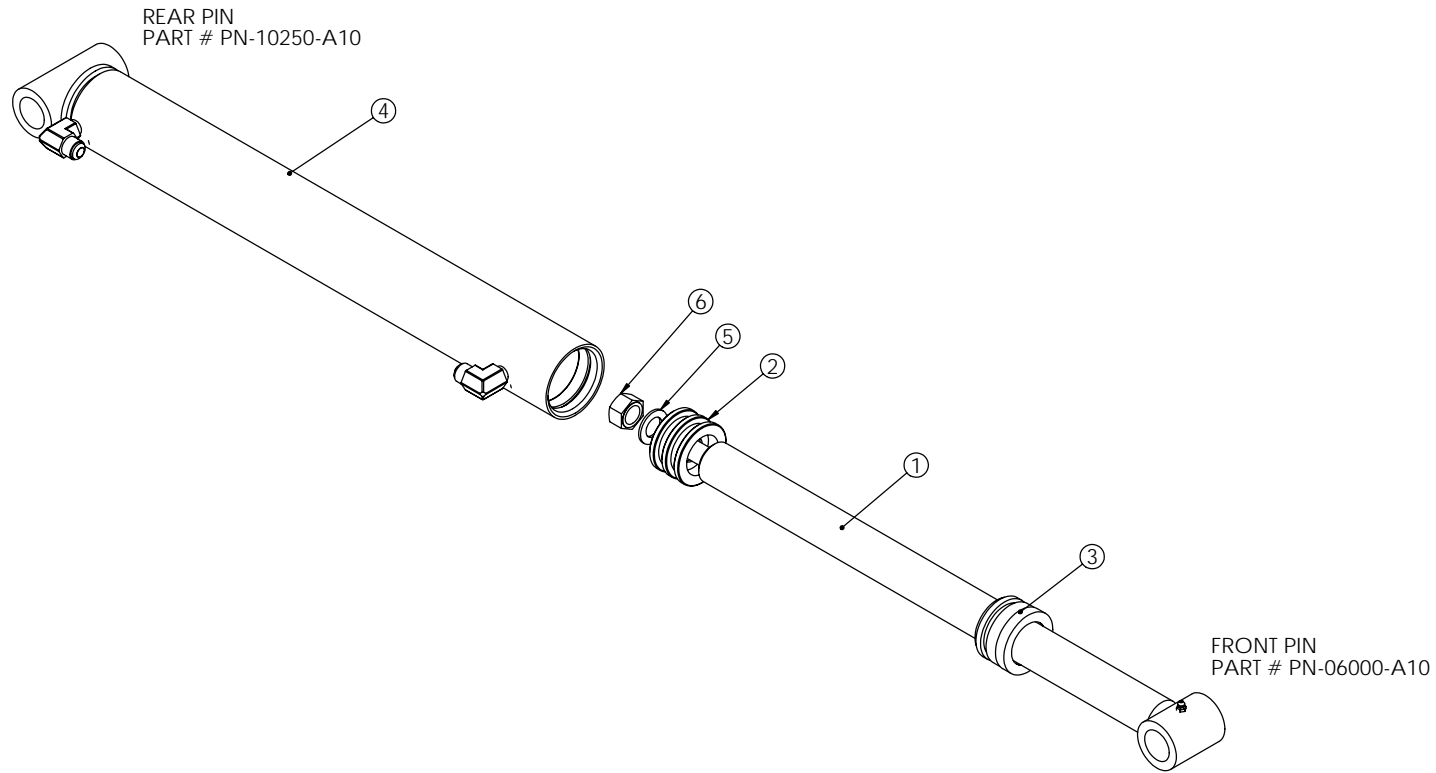

CY-001-LJ
 BUCKET CYLINDER P-12, JIC, LH

NOTES:
 1. PACKING KIT SHOWN IN PART LIST, BUT NOT SHOWN IN DRAWING.

ALL DIMENSIONS IN INCHES

BORE ϕ	2.500
ROD ϕ	1.6250
STROKE	20-3/16"
PORT STYLE	-08 JIC
WEIGHT:	36.175 LBS.

SCHEMATIC

BUCKET CYLINDER P-12, JIC, LH

DWG. NO. **CY-001-LJ**

DATE Wednesday, May 03, 2000 6:10:44 PM

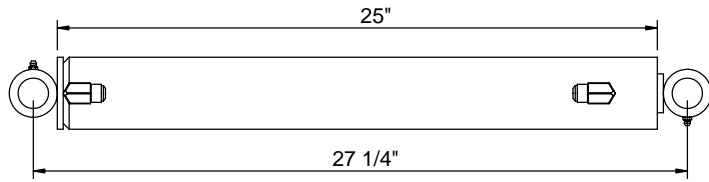

ITEM NO.	PART NUMBER	DESCRIPTION	QTY.
1	CY-001-D	ROD ASSY, P-12 BUCKET	1
2	CP-PS-2516-U	PISTON, 2516 U-CUP	1
3	CP-GL-2516-S	GLAND, 2516 SHORT-TAIL	1
4	CY-001-RJT	TUBE ASSY, P-12 BUCKET (JIC) RIGHT	1
5	HW-WS-12-A	WASHER, 3/4, SAE, PLAIN	1
6	HW-NS-12-E	NUT, 3/4-16 UNF, GRC, TL	1
7	CP-KT-2516-U	P-KIT, 2.500 X 1.625 UC	1

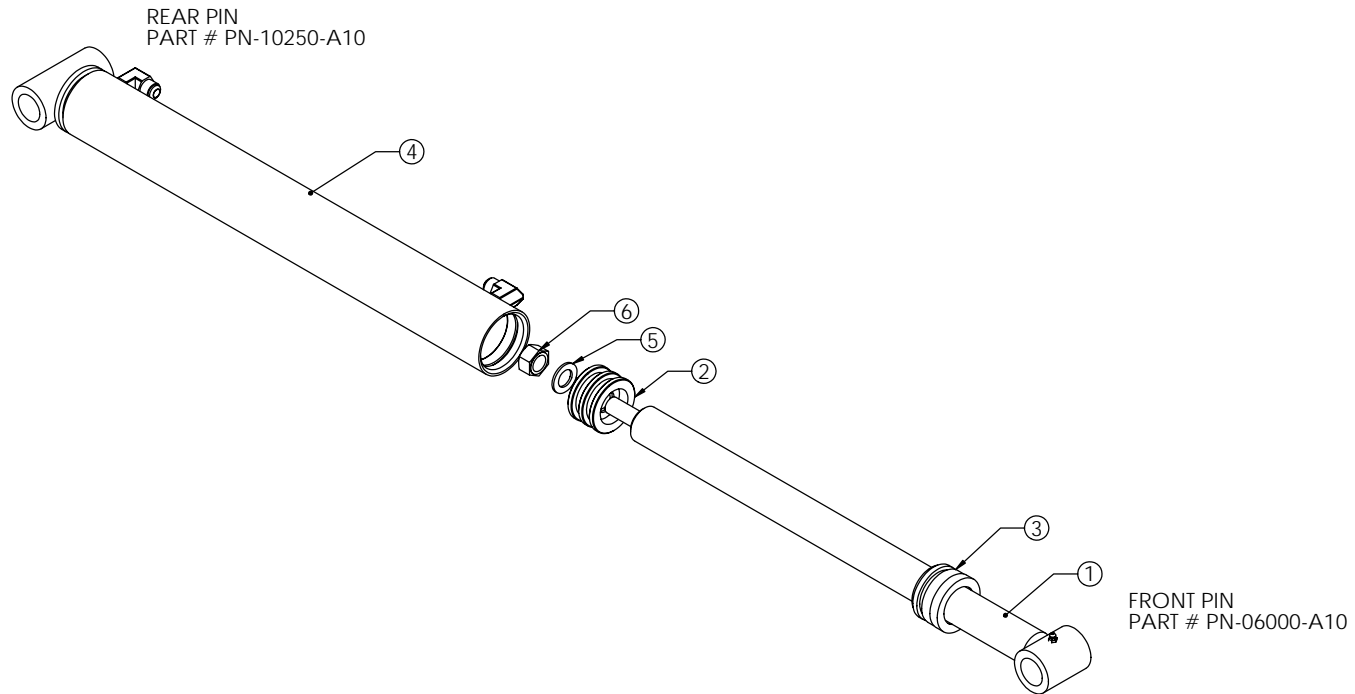

NOTES:
1. PACKING KIT SHOWN IN PART LIST, BUT NOT SHOWN IN DRAWING.

CY-001-RJ
CYLINDER, P-12 BUCKET, LEFT

ALL DIMENSIONS IN INCHES

BORE ϕ	2.500
ROD ϕ	1.625
STROKE	20-3/16"
PORT STYLE	-08 JIC
WEIGHT:	36.175 LBS.

SCHEMATIC
 CYLINDER, P-12 BUCKET, LEFT
 DWG. NO. **CY-001-RJ**
 DATE Thursday, May 04, 2000 9:10:44 AM

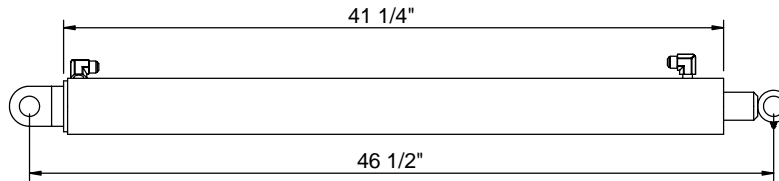

ITEM NO.	PART NUMBER	DESCRIPTION	QTY.
1	CY-002-LJT	TUBE ASSY, P-12 MAINLIFT (JIC) LEFT	1
2	CY-002-D	ROD ASSY, P-12 MAINLIFT	1
3	CP-PS-3017-U	PISTON, 3017 U-CUP	1
4	CP-GL-3017-L	GLAND, 3017, LONG-TAIL	1
5	HW-NS-16-A	NUT, 1-14 UNF, GRC, TL, PLAIN	1
6	CP-KT-3017-U	P-KIT, 3.000 X 1.750 U-CUP	1

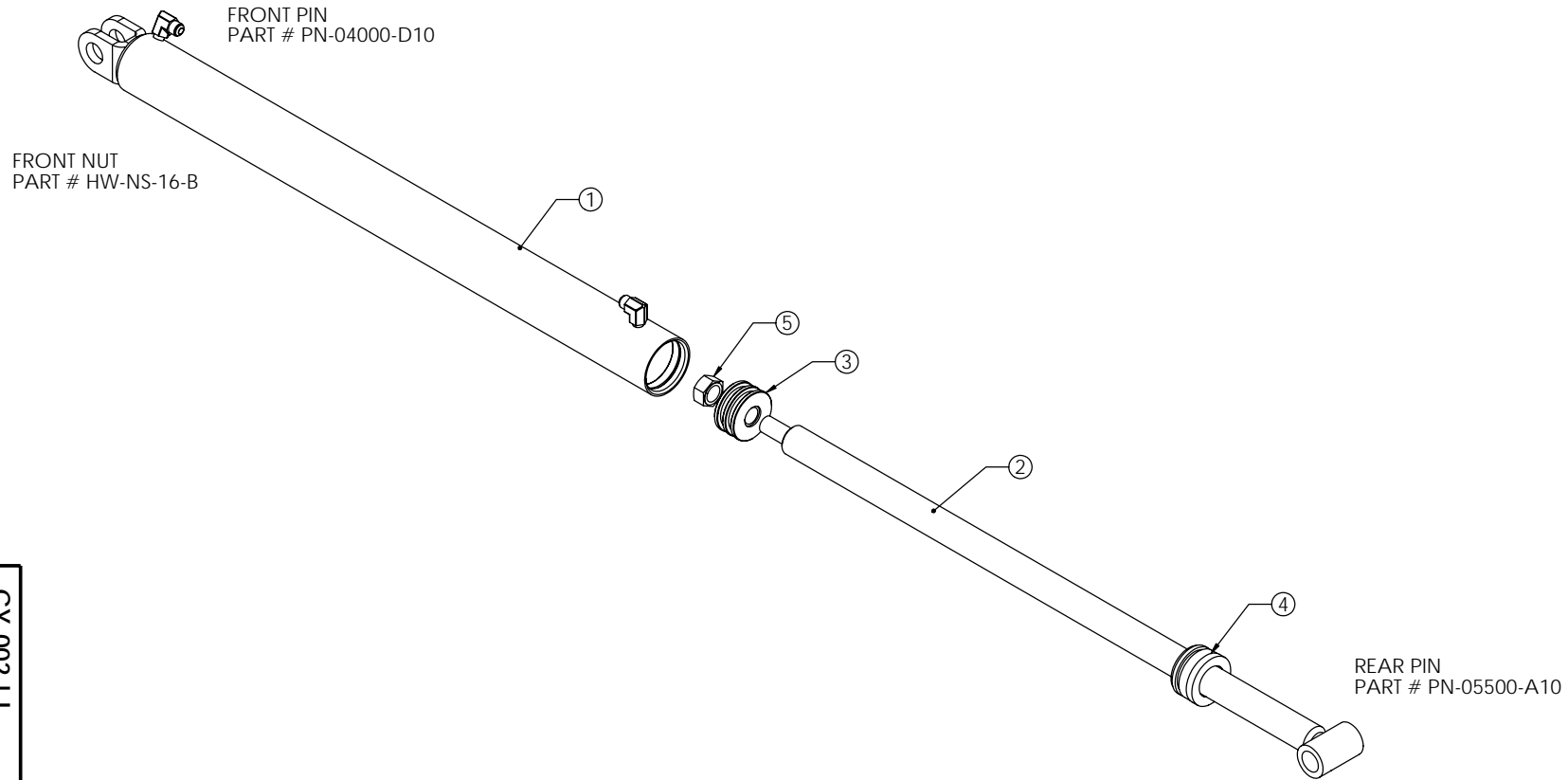

NOTES:
1. PACKING KIT SHOWN IN PART LIST, BUT NOT SHOWN IN DRAWING.

CY-002-LJ
 LIFT CYLINDER, P-12, JIC, LH

ALL DIMENSIONS IN INCHES

BORE ϕ	3.000
ROD ϕ	1.750
STROKE	36-3/8"
PORT STYLE	-08 JIC
WEIGHT:	67.682 LBS.

SCHEMATIC

LIFT CYLINDER, P-12, JIC, LH

DWG. NO. **CY-002-LJ**

DATE Thursday, May 04, 2000 9:10:44 AM

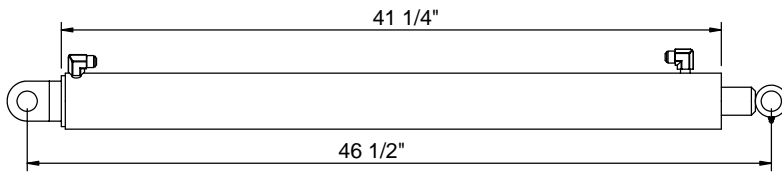

ITEM NO.	PART NUMBER	DESCRIPTION	QTY.
1	CY-002-RJT	TUBE ASSY, P-12 MAINLIFT (JIC) RIGHT	1
2	CY-002-D	ROD ASSY, P-12 MAINLIFT	1
3	CP-PS-3017-U	PISTON, 3017 U-CUP	1
4	CP-GL-3017-L	GLAND, 3017, LONG-TAIL	1
5	HW-NS-16-A	NUT, 1-14 UNF, GRC, TL, PLAIN	1
6	CP-KT-3017-U	P-KIT, 3.000 X 1.750 U-CUP	1

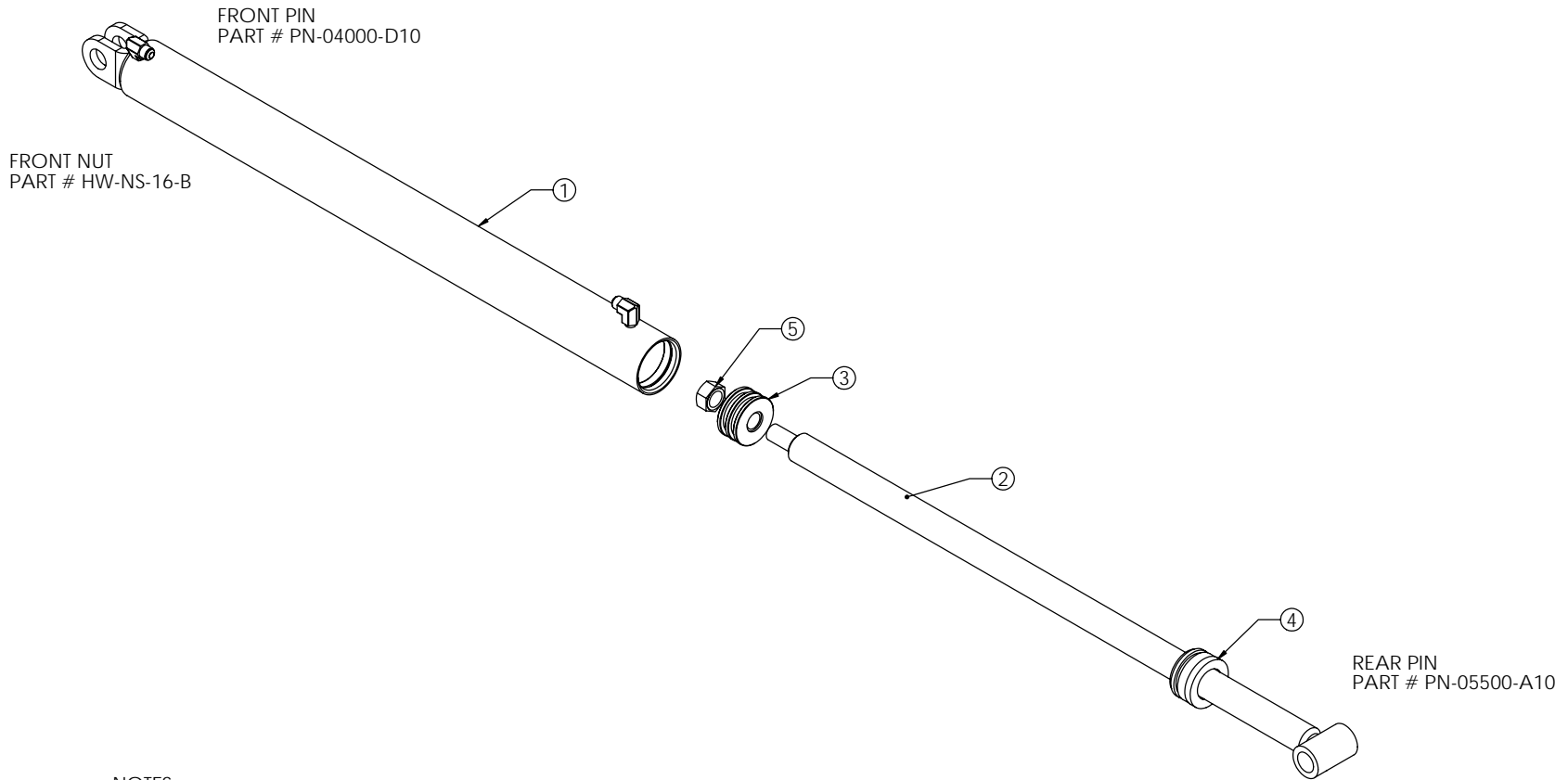

NOTES:
1. PACKING KIT SHOWN IN PART LIST, BUT NOT SHOWN IN DRAWING.

CY-002-RJ
LIFT CYLINDER, P-12, RIGHT

ALL DIMENSIONS IN INCHES

BORE ϕ	3.000
ROD ϕ	1.750
STROKE	36-3/8"
PORT STYLE	-08 JIC
WEIGHT:	67.682 LBS.

better built
MILLER
farm loaders

SCHEMATIC

LIFT CYLINDER, P-12, RIGHT

DWG. NO. **CY-002-RJ**

DATE Thursday, May 04, 2000 9:10:44 AM

SEAL, U-CUP, LARGE

O-RING, LARGE

B/U WASHER

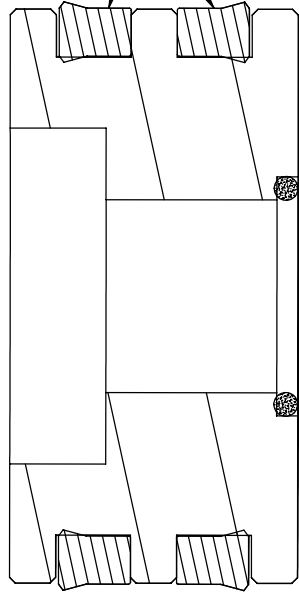

O-RING, SMALL

PISTON

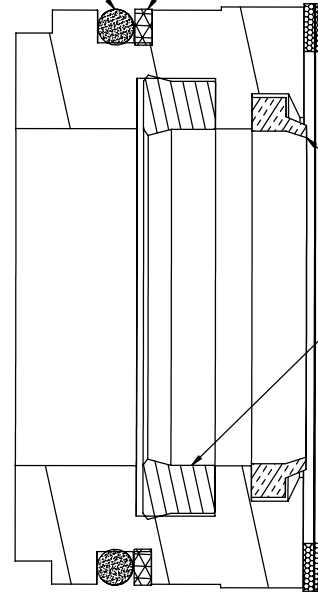

ROD WIPER

SEAL, U-CUP, SMALL

SNAP RING

GLAND

FRONT OF CYLINDER



		<p>SCHEMATIC</p> <p>PACKING CONFIGURATION, U-CUP</p>	
<p>DWG. NO. CP-KT-U</p>		<p>REV. A</p>	
<p>WEIGHT:</p>		<p>DATE 4/20/2005</p>	
		<p>SHEET 1 OF 1</p>	

ITEM NO.	PART NUMBER	DESCRIPTION	QTY.
1	SL01	STAND LEG, P-12	1
2	PIN1-007	CLEVIS PIN, 1 X 2 1/2 ZNC	1
3	PIN1-018	HAIRPIN COTTER, 3-3/4 LONG	1

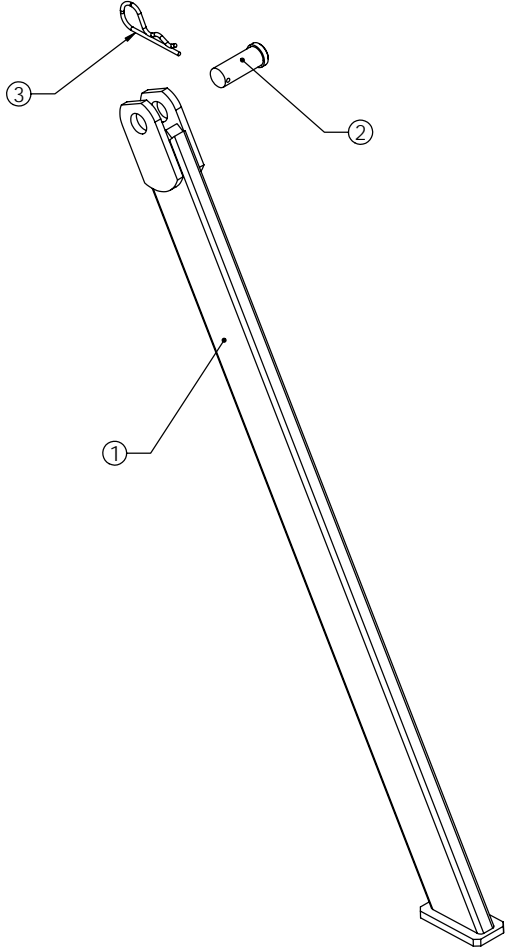

SCHEMATIC

STAND LEG

DWG. NO. SL

WEIGHT:

DATE Friday, May 18, 2001 5:58:39 AM

SHEET 1 OF 1

ITEM NO.	PART NUMBER	DESCRIPTION	QTY.
1	LV01-01	SLIDE TUBE ASSY, LEVEL INDICATOR	1
2	LV01-04	SLIDE ROD ASSY, LEVEL INDICATOR	1
3	LV01-03	LEVEL INDICATOR ROD, 5/8 x 48	1
4	HW-NS-10-B	NUT, 5/8-11 UNC, ZN	1
5	HW-BS-08-0150-A	BOLT, 1/2-13 X 1 1/2 UNC, G5 ZN	1
6	HW-BS-10-0100-A	BOLT, 5/8-11 X 1 UNC, G5 ZN	1
7	HW-WS-08-A	WASHER, 1/2, SAE, ZN	3

COMPLETE ASSEMBLY PART NO: LV01

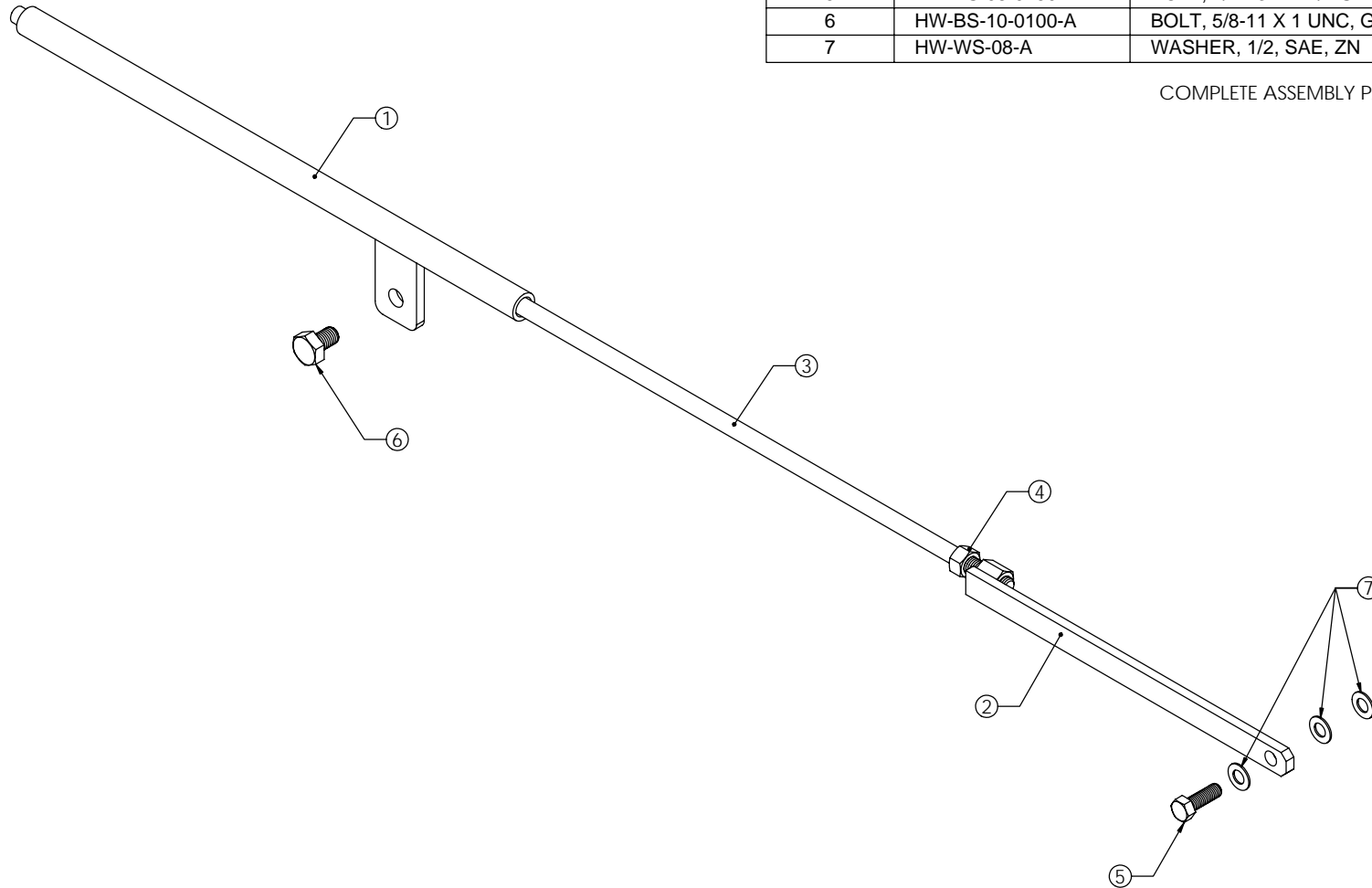

	<h2>SCHEMATIC</h2>
	<h3>LEVEL INDICATOR KIT</h3>
DWG. NO. LV	
WEIGHT: 9.838 LB.	DATE Thursday, May 04, 2000 9:10:44 AM
SHEET 1 OF 1	

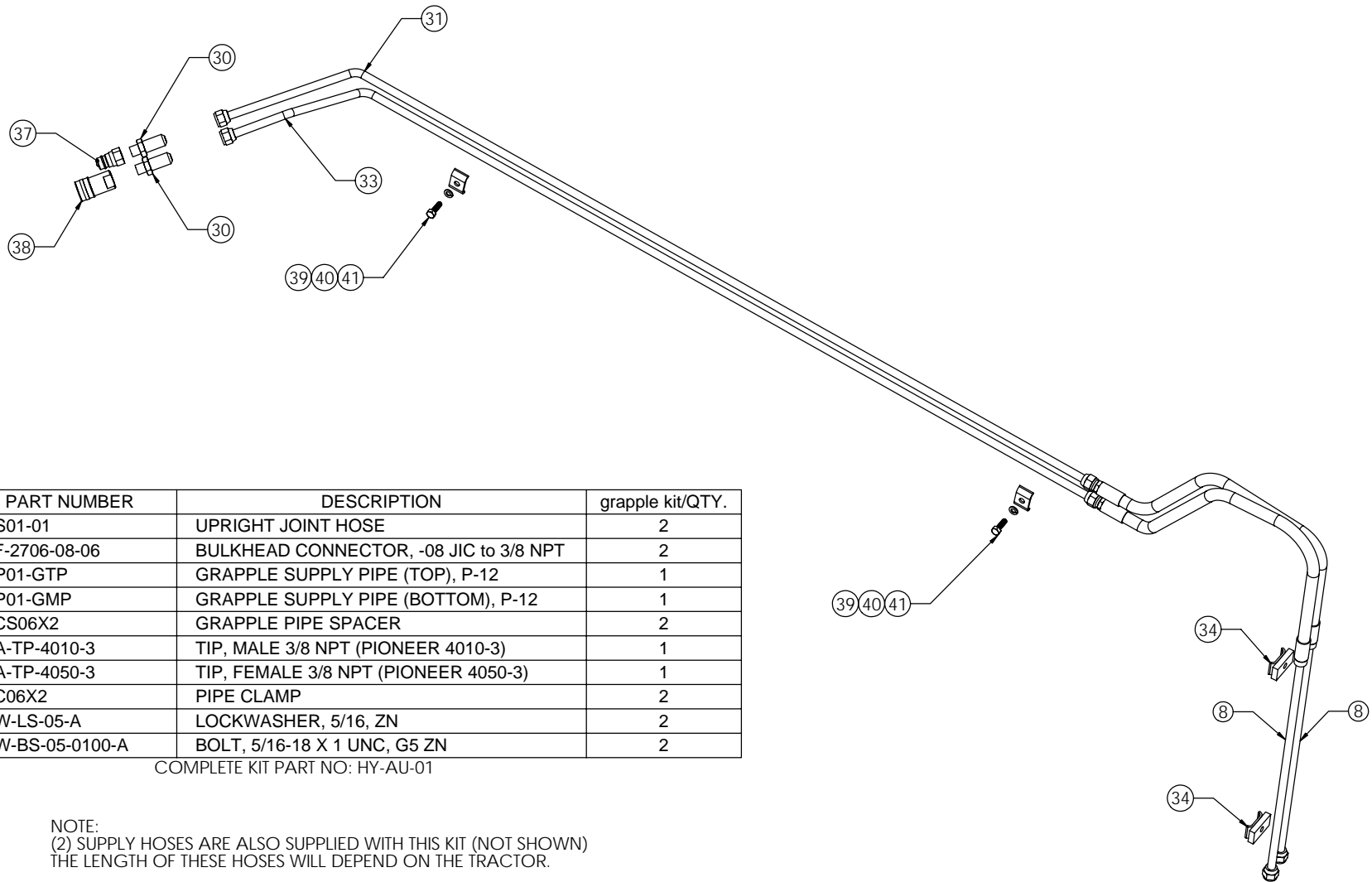

ITEM NO.	PART NUMBER	DESCRIPTION	grapple kit/QTY.
8	HS01-01	UPRIGHT JOINT HOSE	2
30	SF-2706-08-06	BULKHEAD CONNECTOR, -08 JIC to 3/8 NPT	2
31	HP01-GTP	GRAPPLE SUPPLY PIPE (TOP), P-12	1
33	HP01-GMP	GRAPPLE SUPPLY PIPE (BOTTOM), P-12	1
34	PCS06X2	GRAPPLE PIPE SPACER	2
37	HA-TP-4010-3	TIP, MALE 3/8 NPT (PIONEER 4010-3)	1
38	HA-TP-4050-3	TIP, FEMALE 3/8 NPT (PIONEER 4050-3)	1
39	PC06X2	PIPE CLAMP	2
40	HW-LS-05-A	LOCKWASHER, 5/16, ZN	2
41	HW-BS-05-0100-A	BOLT, 5/16-18 X 1 UNC, G5 ZN	2

COMPLETE KIT PART NO: HY-AU-01

NOTE:
 (2) SUPPLY HOSES ARE ALSO SUPPLIED WITH THIS KIT (NOT SHOWN)
 THE LENGTH OF THESE HOSES WILL DEPEND ON THE TRACTOR.



MILLER
farm loaders

SCHEMATIC

AUX. OIL LINE KIT
HY-AU-01

DWG. NO. HP01GK

WEIGHT:
DATE Tuesday, December 17, 2002 2:08:50 PM
SHEET 1 OF 1



WARRANTY

Dec 2004

ALL PRODUCTS MANUFACTURED BY MILLER LOADERS, INCORPORATED (**MLI**) EXCEPT THE CHROME-PLATED PIVOT PINS USED ON GREASELESS LOADERS, ARE GUARENTEED TO THE ORIGINAL PURCHASER FOR A PERIOD OF ONE YEAR FROM THE DAY OF PURCHASE AGAINST ANY DEFECTS IN MATERIALS AND WORKMANSHIP OF FARM LOADERS AND ATTACHMENTS THAT ARE USED IN NORMAL FARM OPERATIONS. THE CHROME-PLATED PIVOT PINS USED ON GREASELESS LOADERS ARE GUARENTEED TO THE ORIGINAL PURCHASER FOR A PERIOD OF FIVE YEARS FROM THE DAY OF PURCHASE AGAINST ANY DEFECTS IN MATERIALS AND WORKMANSHIP OR AGAINST WEAR THROUGH OF THE CHROME FINISH COVERING AT LEAST ONE-QUARTER OF THE PIN SURFACE.

ALL GREASELESS COMPOSITE BEARINGS SOLD BUT NOT MANUFACTURED BY **MLI** ARE GUARENTEED TO THE ORIGINAL PURCHASER FOR A PERIOD OF FIVE YEARS FROM THE DAY OF PURCHASE AGAINST BREAKAGE OR LOSS OF THEIR SELF-LUBRICATING PROPERTY.

THE FIVE YEAR WARRANTY FOR THE CHROME-PLATED PIVOT PINS AND GREASELESS COMPOSITE BEARINGS IS LIMITED TO THE PARTS ONLY. **MLI** IS NOT RESPONSIBLE FOR ANY LABOR NECESSARY FOR THE INSPECTION, REMOVAL, OR REPLACEMENT OF SAID PIVOT PINS AND/OR COMPOSITE BEARINGS.

ALL PARTS SOLD BUT NOT MANUFACTURED BY **MLI** THAT INCLUDE BUT ARE NOT LIMITED TO ZINC-PLATED PINS, HOSES, VALVES, QUICK COUPLERS, PUMPS, TANKS, ETC. ARE COVERED ONLY TO THE EXTENT OF THE MANUFACTURE'S WARRANTY ON THESE ITEMS. **MLI** DOES NOT WARRANTY THESE ITEMS EXPRESSLY OR IMPLIEDLY.

DEFACEMENT OF ANY PART BY WELDING OR OTHERWISE ALTERING, OR EXCESSIVE WEAR ON PINS CAUSED BY LACK OF LUBRICATION, NULLIFIES THE WARRANTY ON THE **MLI** PRODUCT.

MLI ASSUMES NO RESPONSIBILITY AS TO THE PERFORMANCE OR FAILURE OF A TRACTOR'S HYDRAULIC SYSTEM.

THE HYDRAULIC COMPONENTS OF THE **MLI** PRODUCTS ARE GUARENTEED UP TO A PRESSURE OF 3000 POUNDS PER SQUARE INCH AT A MAXIMUM FLOW RATE OF 30 GALLONS PER MINUTE.

MLI ASSUMES NO RESPONSIBILITY FOR THE FAILURE OF THE PURCHASER TO SECURE THE LOADER TO THE TRACTOR PROPER, WHICH INCLUDES PROPER BOLT TIGHTENING AND SECURING OF ALL CONNECTION POINTS.

ALL ITEMS MANUFACTURED BY **MLI** REQUIRING WARRANTY CONSIDERATION MUST BE RETURNED TO **MLI** OR A DESIGNATED REPRESENTATIVE BY THE ORIGINAL PURCHASER. ANY ITEM SO RETURNED BY COMMON CARRIER MUST BE PREPAID FREIGHT.

THE WARRANTIES PROVIDED BY **MLI** AS REFERRED TO ABOVE SHALL BE THE SOLE AND EXCLUSIVE WARRANTIES. THERE SHALL BE NO OTHER WARRANTIES EXPRESS OR IMPLIED INCLUDING ANY IMPLIED WARRANTY OF MERCHANTABILITY OR FITNESS OR ANY OTHER OBLIGATION ON THE PART OF **MLI** WITH RESPECT TO PRODUCTS COVERED BY THIS WARRANTY.

IN NO EVENT SHALL THE WARRANTIES OF **MLI** REQUIRE MORE FROM **MLI** THAN THE REPAIR OR REPLACEMENT OF ANY PART OR PARTS WHICH ARE FOUND TO BE DEFECTIVE WITHIN THE EFFECTIVE PERIOD OF THE WARRANTY, **MLI** SHALL HAVE NO LIABILITY FOR ANY INCIDENTAL OR CONSEQUENTIAL DAMAGES.

MILLER LOADERS INC, 1242 ARIZONA AVE, LARCHWOOD, IA 51241

PHONE: 1-800-570-8205
Or (712) 477-2795

FAX: (712) 477-2500