



OWNER'S MANUAL



GL30 LOADER **PARTS and INSTRUCTIONS**

1242 ARIZONA AVE.
LARCHWOOD, IA 51241
1-800-570-8205



DANGER



**TO PREVENT POSSIBLE ROLLOVER, OBSERVE THE FOLLOWING
SAFETY PRECAUTIONS**

- ◆ Carry loads as low as possible
- ◆ Drive tractor slowly when turning, operating on hills or inclines, or traversing uneven ground
- ◆ Raise load to full height *only* when tractor is on even ground and front wheels are straight ahead

**TO PREVENT POSSIBLE PERSONAL INJURY, OBSERVE THE FOLLOW-
ING SAFETY PRECAUTIONS**

- ◆ Never walk or work under a raised loader that is not firmly supported
- ◆ Always relieve the hydraulic system to zero pressure before performing repairs on any component of the loader's hydraulic system

TABLE OF CONTENTS

- Composite Bearing Information
- Installing Mounts onto Tractor
- Mounting Loader on Tractor
- Dismounting Loader
- Quick-attach Instructions
- Parts Schematics
- Cylinder Packing Detail
- Loader Specifications
- Warranty

SERIAL No. of Loader Purchased _____

COMPOSITE BEARING INFORMATION

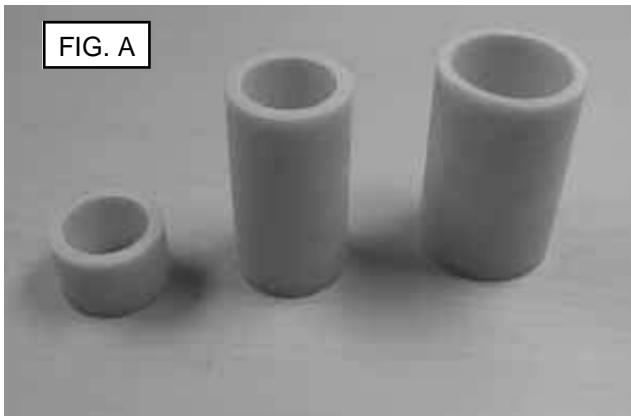

FIGURE A. Your GP/GL-Series loader is equipped with composite, greaseless bearings at all (12) pivot points. These high-quality bearings should not be confused with plastic bushings, sintered bushings, or metal-backed bearings. Composite bearings are made from an ultra-strong fiberglass composite that has twice the compressive yield strength of plain carbon steel. Their greaseless feature is due to a Teflon-impregnated liner that is interwoven to the bearing's inside diameter. The bearings are designed to last the life of the loader and the pins that rotate in the bearings should exhibit practically no wear.

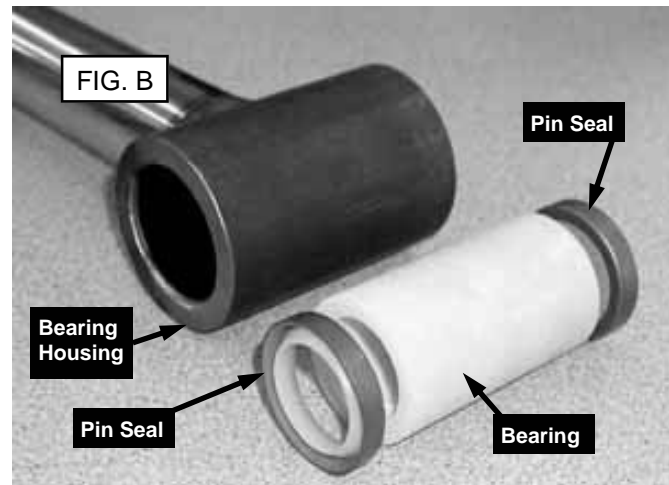

FIGURE B. Even though the composite bearings on your GP/GL-Series loader have excellent resistance to dirt particles, (10) of the (12) pivot points on the loader have an added feature. They are equipped with pin seals on each end of the bearing housing. These seals do an excellent job of keeping out dirt, grime, manure and fertilizer dust.

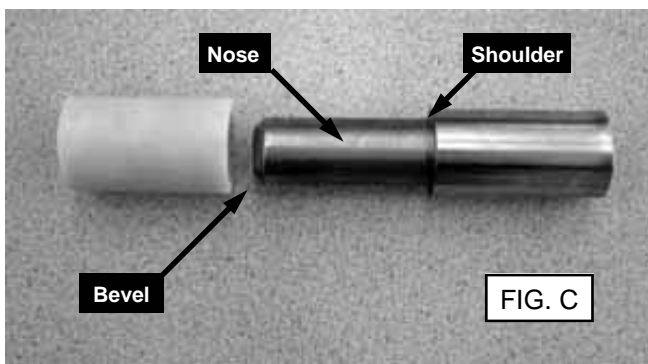
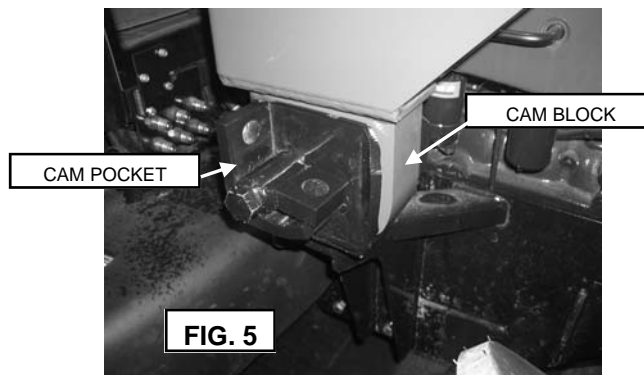
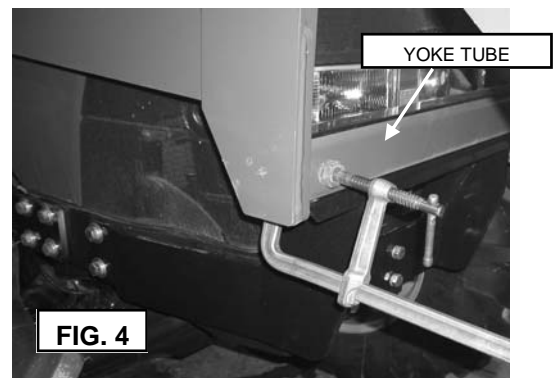
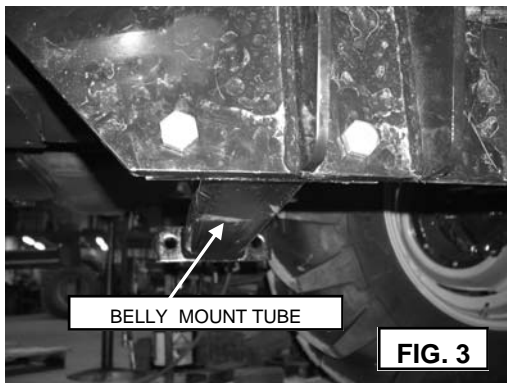
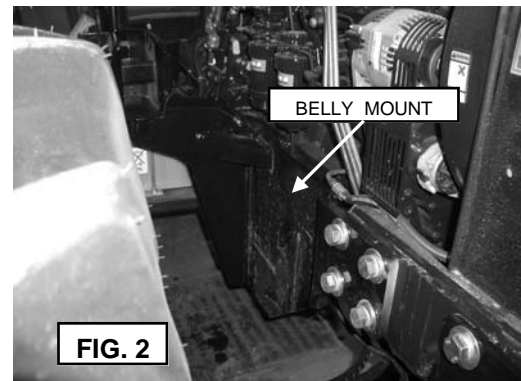
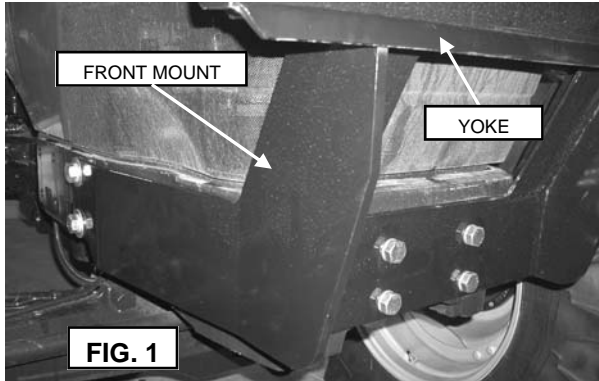

FIGURE C. Should any of your bearings have to be removed, this photo shows the tool that is available to remove and install the bearings properly. They are available for purchase, you just need to tell your dealer or Miller Loaders the model of loader you have. If you'd prefer to make your own, here are a few things to remember:

- The nose should be 1/4" longer than the bearing
- A 1/4" bevel on the end of the nose
- The shoulder must be just slightly smaller than the outside diameter of the bearing
- The diameter of the nose should be about 0.005 less than the inside diameter of the bearing

INSTALL MOUNTS ON TRACTOR



STEP 1 Install the front mount onto the front casting of the tractor. Tighten all bolts that secure the front mount. See Figure 1.

STEP 2 Install the belly mounts onto the tractor—one on the right side and one on the left side. Install the bolts and washers, but **DO NOT TIGHTEN THEM YET!** The belly mounts must be able to move back and forth in the following steps. See Figure 2.

STEP 3 Install the belly mount tube that hangs in between the belly mounts. Loosely connect the bolts and nuts, do not tighten these yet either. See Figure 3.

STEP 4 Drive into the loader so that the yoke tube of the loader slides into the yoke of the front mount. Use (2) C-clamps (one on each side of the yoke tube) to fully seat the tube into the yoke and secure it. See Figure 4.

STEP 5 The cam blocks of the loader should be positioned in the cam pockets as shown in Figure 5.

INSTALL MOUNTS ON TRACTOR

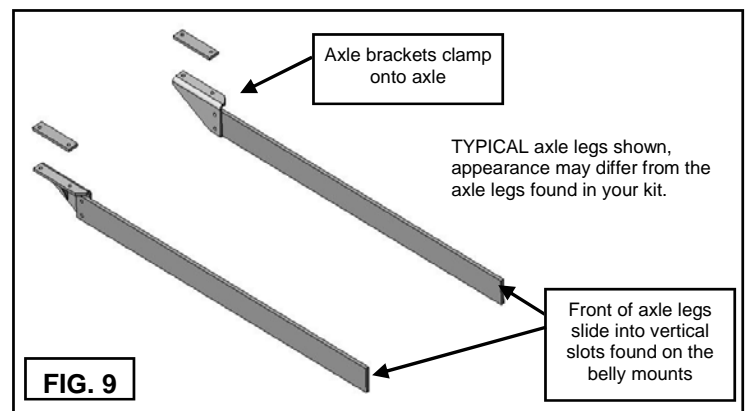
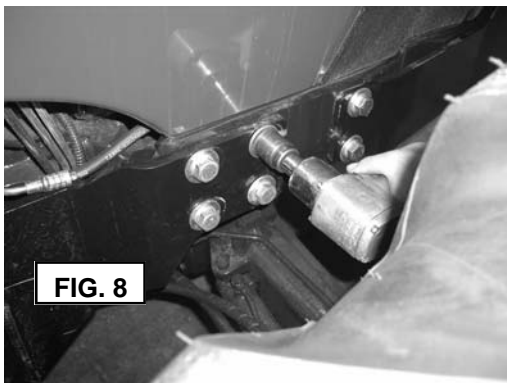
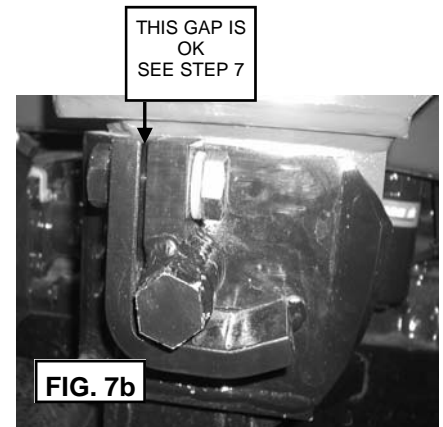
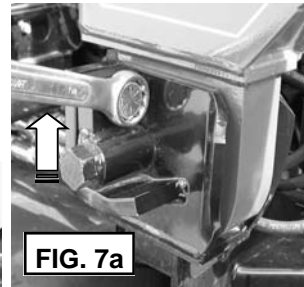
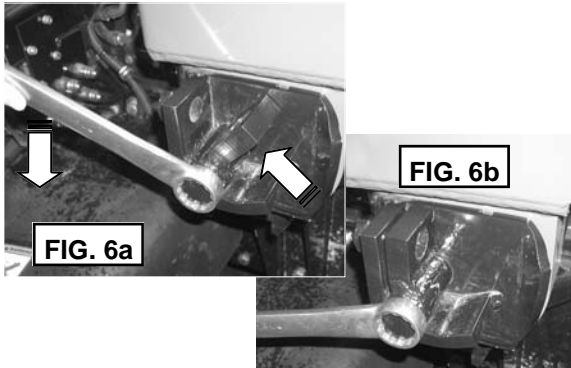

STEP 6 Use a 1-1/2" wrench to turn the cam which pulls the cam block into the pocket. Since the loader was secured to the front mount with c-clamps in Step 4, the belly mounts will shift slightly as the cam is rotated. This is normal. See Figures 6a and 6b.

STEP 7 With a 1-1/2" end wrench or socket wrench (**Not** an impact wrench or cheater bar!) tighten the 1" bolt that secures the cam. See Figures 7a and 7b. **Important!** The gap shown in Figure 7b is the proper gap after tightening. The gap is supposed to be this way. Do not think you have to tighten the bolt until the gap is closed.

STEP 8 Now that the mounts are in the proper position and the cam bolts are tight, all of the belly mount bolts can be tightened. See Figure 8. Remove the c-clamps that were used in Step 4. If your mount kit includes axle legs, proceed to Step 9, otherwise, your mount installation is complete.

STEP 9 Some mounting kits include axle legs and axle brackets. See Figure 9. Hang the axle brackets from the tractor's axle without tightening the bolts. Usually the narrow end of the bracket is to the rear. Insert the front of the axle legs into the 1" x 5" slots found on the belly mounts. Bolt the rear of the axle legs to the axle brackets. Tighten the bolts that are clamping the brackets to the axle. The final step is to tighten the 5/8 set-screw (bolt) on the belly mount that is pressing down on the very front of the axle leg. The purpose of the axle legs is to protect the bolted connections on the tractor (i.e., motor to tranny, tranny to bull gear) in the event the rear axle is unweighted during loader operation and the rear tires are no longer supporting the tractor. Whether or not your mounting kit included axle legs depends on the construction of the tractor. Most newer tractors do not require axle legs.

MOUNTING INSTRUCTIONS

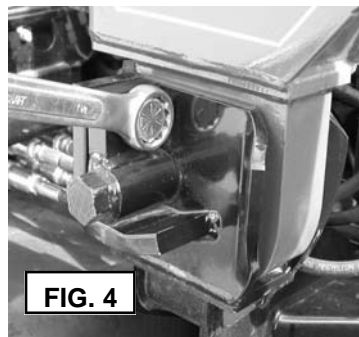
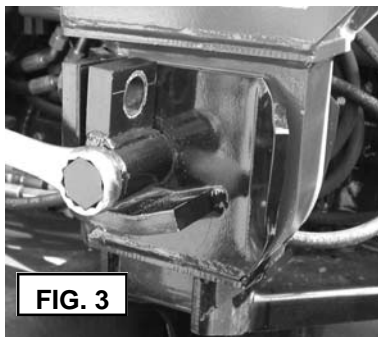
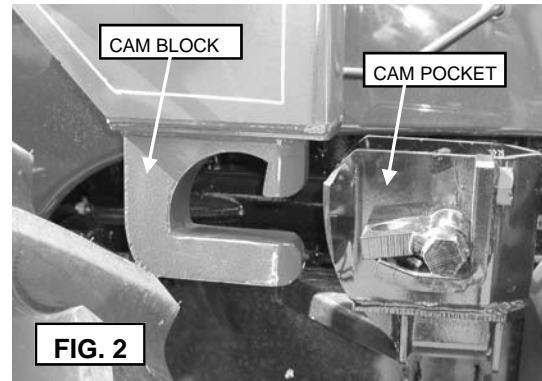

STEP 1 Approach the loader slowly and place the tractor close enough to allow the connection of the hydraulic hoses. Connect the hoses to the tractor so that the loader can be operated. See Figure 1.

STEP 2 Tilt the bucket down slowly so that the cam block on the loader aligns with the cam pocket on the mountings. See Figure 2. Slowly drive the tractor forward so that the cam blocks slide into the cam pockets and the front tube slides into the yoke tube on the front of the loader.

STEP 3 Use a 1-1/2" wrench to turn the cam which pulls the cam block into the pocket. It needs only to be engaged enough so that the 1" bolt can be installed in the hole and the threads started. See Figures 3 and 4.

STEP 4 Tighten the 1" bolt that secures the cam. See Figure 4.

STEP 5 Raise the loader off the ground. Retract the stand legs and position them in their stored location. See Figure 5.

DISMOUNT INSTRUCTIONS

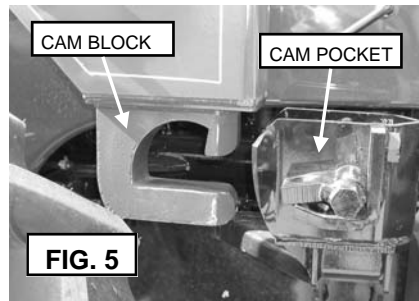
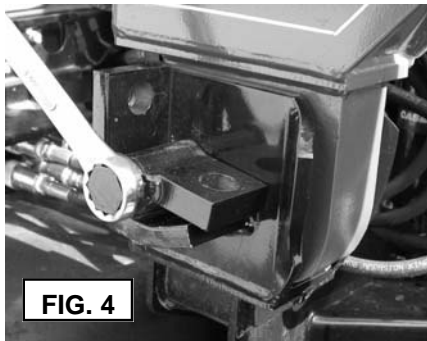
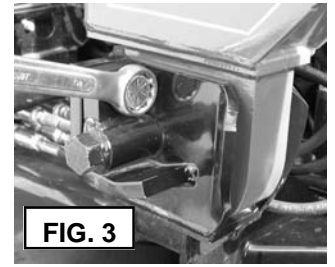

STEP 1 *DRIVE ONTO FLAT, LEVEL CONCRETE.* Raise the loader and place the stand legs in the position shown in Figure 1.

STEP 2 Gently lower the loader until the stand legs rest on the ground. Tilt the bucket forward until the cutting edge is also resting on the ground. See Figure 2.

STEP 3 Loosen and remove the 1" bolts that secure the cams on both sides of the loader. See Figure 3.

STEP 4 Use a 1-1/2" wrench to turn the cams forward. See Figure 4.

STEP 5 Slowly back up the tractor until the cam blocks are free from the cam pockets. See Figure 5.

STEP 6 Slowly roll the bucket until it is flat on the ground. This motion will also tilt the loader up to its stored position. Disconnect the hydraulic hoses and back away from the loader. See Figure 6.

QUICK-ATTACH INSTRUCTIONS

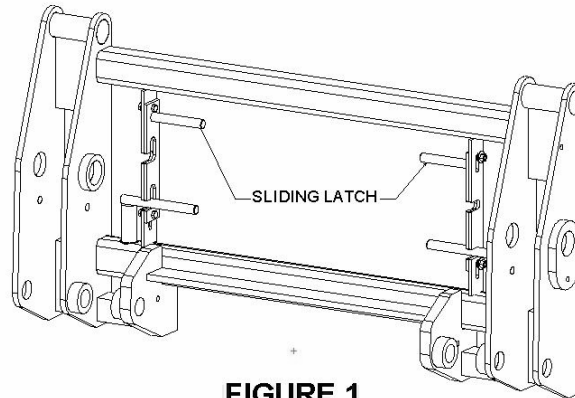

FIGURE 1.

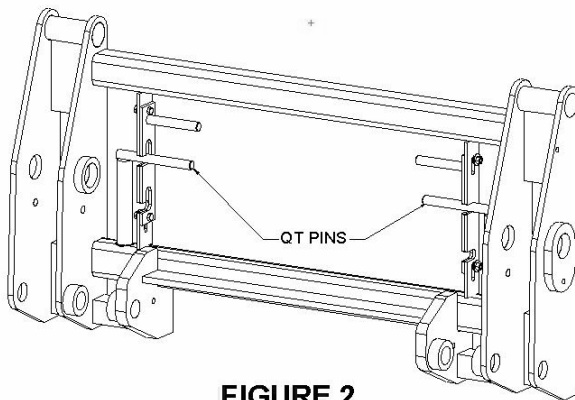

FIGURE 2.

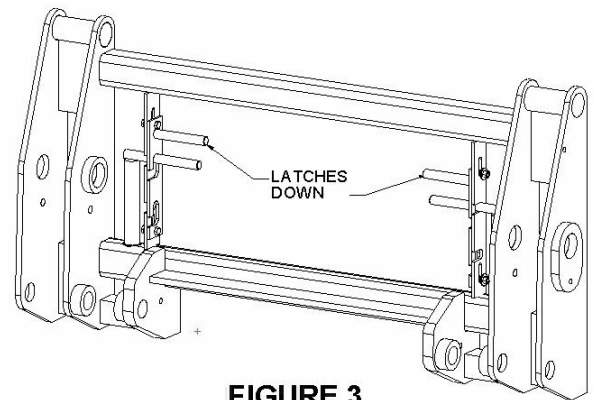

FIGURE 3.

UNCOUPLING

1. Raise sliding latches as shown in Figure 1.
2. Rotate QT pins out of the lower notches, raise, and then rotate them into the upper notches of the sliding latches as shown in Figure 2.
3. Slide the sliding latches down as shown in Figure 3. This secures the QT pins in the “up” position so they do not interfere when hooking up to the next attachment.

COUPLING

1. Approach and hook onto the attachment with QT pins secured in the “up” position as shown in Figure 3.
2. When the QT frame is flat against the attachment, raise the sliding latches as shown in Figure 2.
3. Rotate QT pins out of the upper notches, lower, and then rotate them into the lower notches on the sliding latches as shown in Figure 1. **NOTE:** If the QT pins do not easily slide thru the lug on the attachment, do not force them. Simply rotate the attachment back and forth slowly with the bucket cylinders of the loader and the QT pins should fall into place. Periodically grease the QT pins and sliding latches.
4. Secure the QT pins in the “down” position by sliding the latches down.

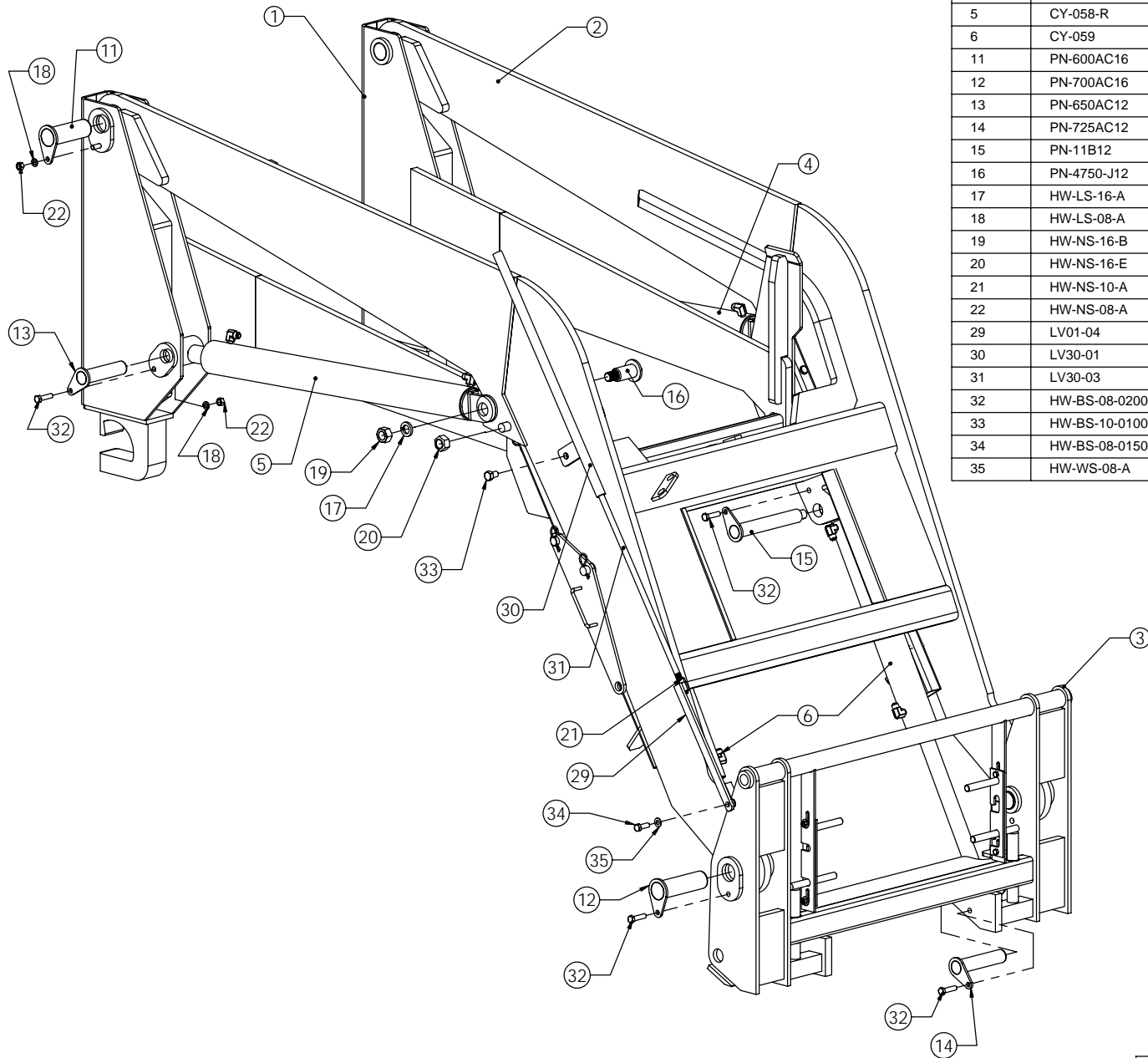

ITEM NO.	PART NUMBER	DESCRIPTION	Default/QTY.
1	UR30	UPRIGHT FRAME, GL30	1
2	MF30	MAINFRAME, GL30/GP30	1
3	QT30	QUICK ATTACH FRAME	1
4	CY-058-L	CYLINDER, GL30 LIFT (LH)	1
5	CY-058-R	CYLINDER, GL30 LIFT (RH)	1
6	CY-059	CYLINDER, BUCKET, GL/GP30	2
11	PN-600AC16	PIN, CHROME 2" x 6" WITH RETAINER	2
12	PN-700AC16	PIN, CHROME 2" x 7" WITH RETAINER	2
13	PN-650AC12	PIN, CHROME 1-1/2 x 6-1/2 WITH RETAINER	2
14	PN-725AC12	PIN, CHROME 1-1/2 x 7-1/4 WITH RETAINER	2
15	PN-11B12	REAR BUCKET CYLINDER PIN	2
16	PN-4750-J12	LIFT CYLINDER PIN, 1-1/2 CHROME	2
17	HW-LS-16-A	LOCKWASHER, 1-IN., MED ZN	2
18	HW-LS-08-A	LOCKWASHER, 1/2, MED ZN	10
19	HW-NS-16-B	NUT, 1-14 UNF, GR5, NZ	2
20	HW-NS-16-E	NUT, 1-14 UNF GR8 TL, ZN	2
21	HW-NS-10-A	NUT, 5/8-11 UNC GR8, ZN	1
22	HW-NS-08-A	NUT, 1/2-13 UNC, ZN	10
29	LV01-04	SLIDE ROD ASSY, LEVEL INDICATOR	1
30	LV30-01	SLIDE TUBE ASSY, LEVEL INDICATOR	1
31	LV30-03	LEVEL INDICATOR ROD, GL/GP30	1
32	HW-BS-08-0200-A	BOLT, 1/2-13 UNC, GR5 ZN, 2" LONG	8
33	HW-BS-10-0100-A	BOLT, 5/8-11 UNC, GR5 ZN, 1" LONG	1
34	HW-BS-08-0150-A	BOLT, 1/2-13 UNC, GR5 ZN, 1-1/2" LONG	1
35	HW-WS-08-A	WASHER, 1/2" FLAT, ZN	3

MILLER SCHEMATIC
 farm loaders

GL30 LOADER
GENERAL PART LIST

DWG. NO. GL30	REV. A
WEIGHT: 2500.015	DATE 1/13/2005
SHEET 1 OF 1	

ITEM NO.	PART NUMBER	DESCRIPTION	with bearings/QTY.
20	BR-2500K-3750	COMPOSITE BEARING, 2.00 BORE, 3.75 LONG	2
21	PS-2000-45	Pin Seal (MRW), 2.0 ID x 2.5 OD x 5/16 Thick	8
22	BR-2000K-1500	COMPOSITE BEARING, 1.50 BORE, 1.50 LONG	2
23	BR-2500K-3125	COMPOSITE BEARING, 2.00 BORE, 3.125 LONG	2

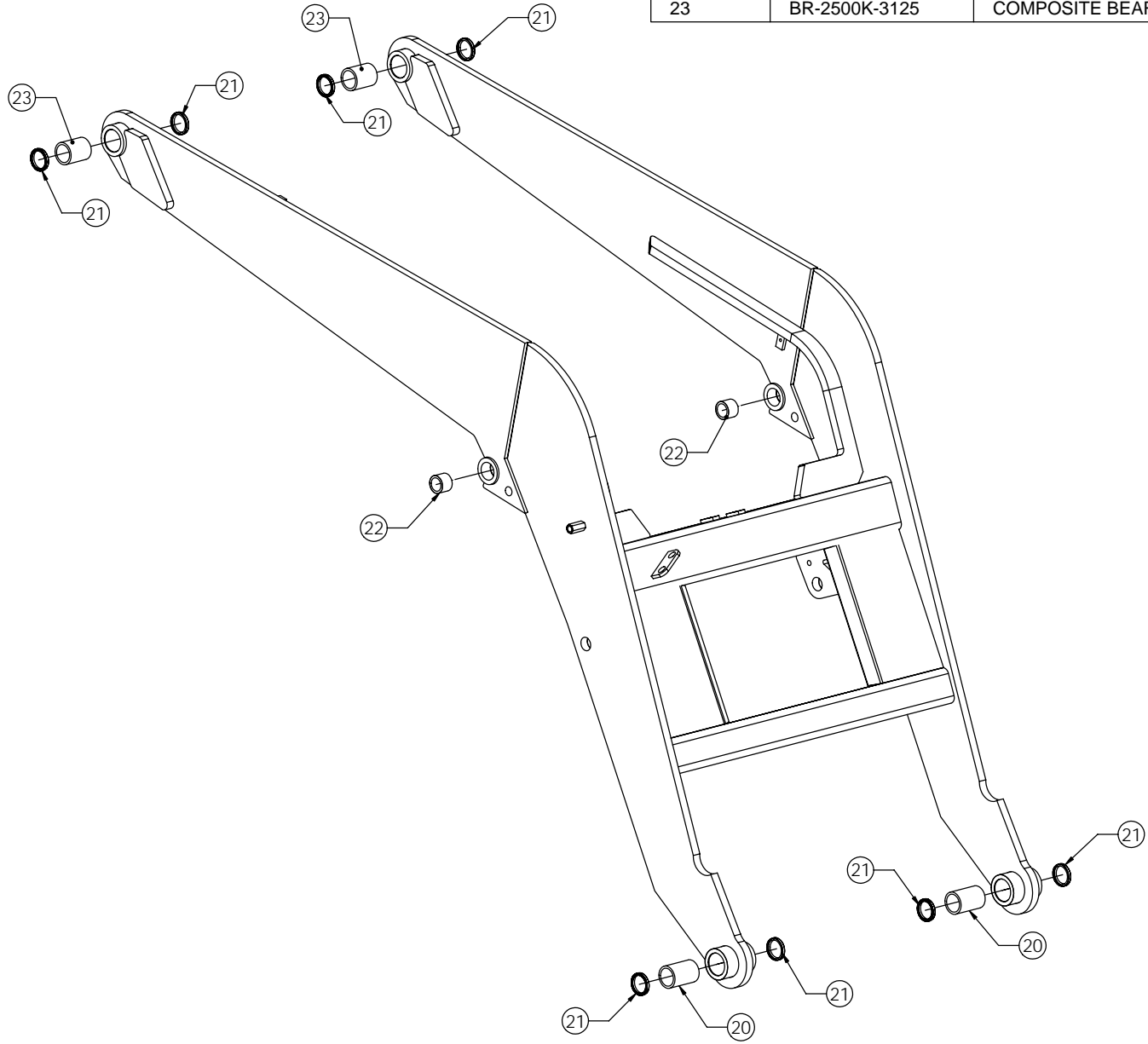



MILLER SCHEMATIC
 farm loaders

MAINFRAME, GL30/GP30
 BEARING & SEAL DETAIL

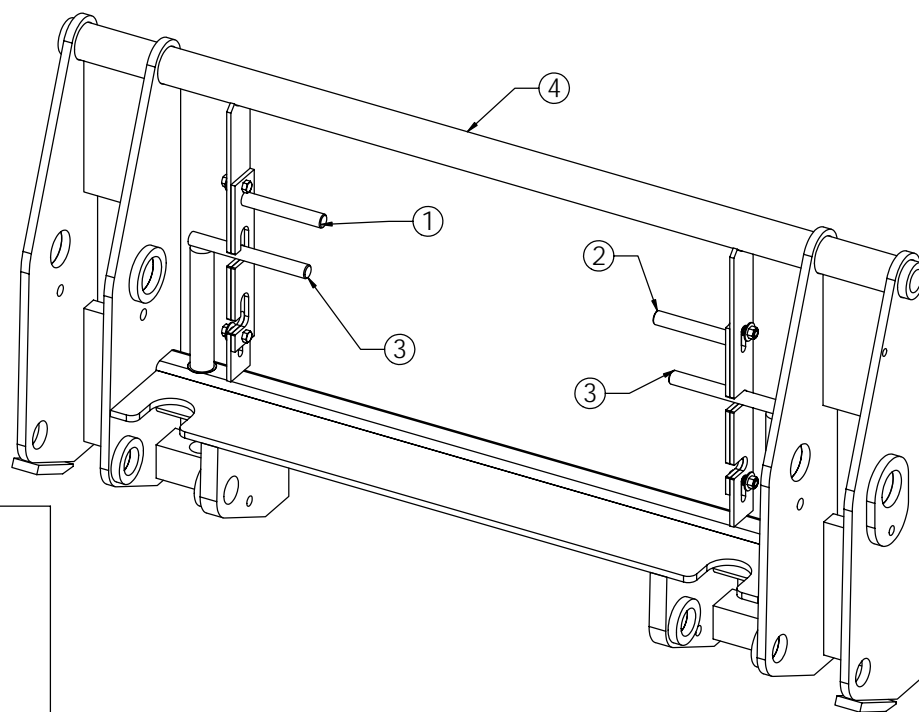
DWG. NO. MF30	REV. A
WEIGHT: 1159.886	DATE 1/28/2005
SHEET 1 OF 1	

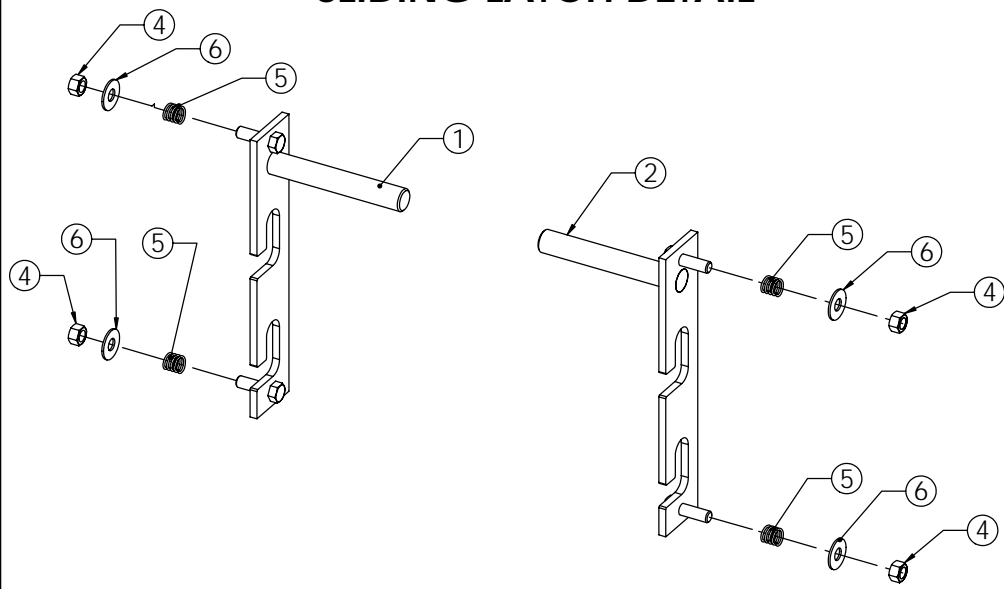

SLIDING LATCH DETAIL



ITEM NO.	PART NUMBER	DESCRIPTION	Pin Up Latch Up/QTY.
1	QT02-01L	SLIDING LATCH ASSY, QT, LH	1
2	QT02-01R	SLIDING LATCH ASSY, QT, RH	1
3	QT02-14	RETAINING PIN ASSEMBLY, QT	2
4	QT30-W	WELDED QT FRAME	1

ITEM NO.	PART NUMBER	DESCRIPTION	QTY.
4	HW-NS-06-A	NUT, 3/8-16 UNC, CL, ZN	4
5	HW-SP-01	SPRING, QT HANDLE	4
6	HW-WS-06-A	WASHER, 3/8, FLAT, ZN	4



QUICK ATTACH FRAME
GL30/GP30/GP35

DWG. NO. QT30	REV. A
WEIGHT: 246.509	DATE 1/13/2005
SHEET 1 OF 1	

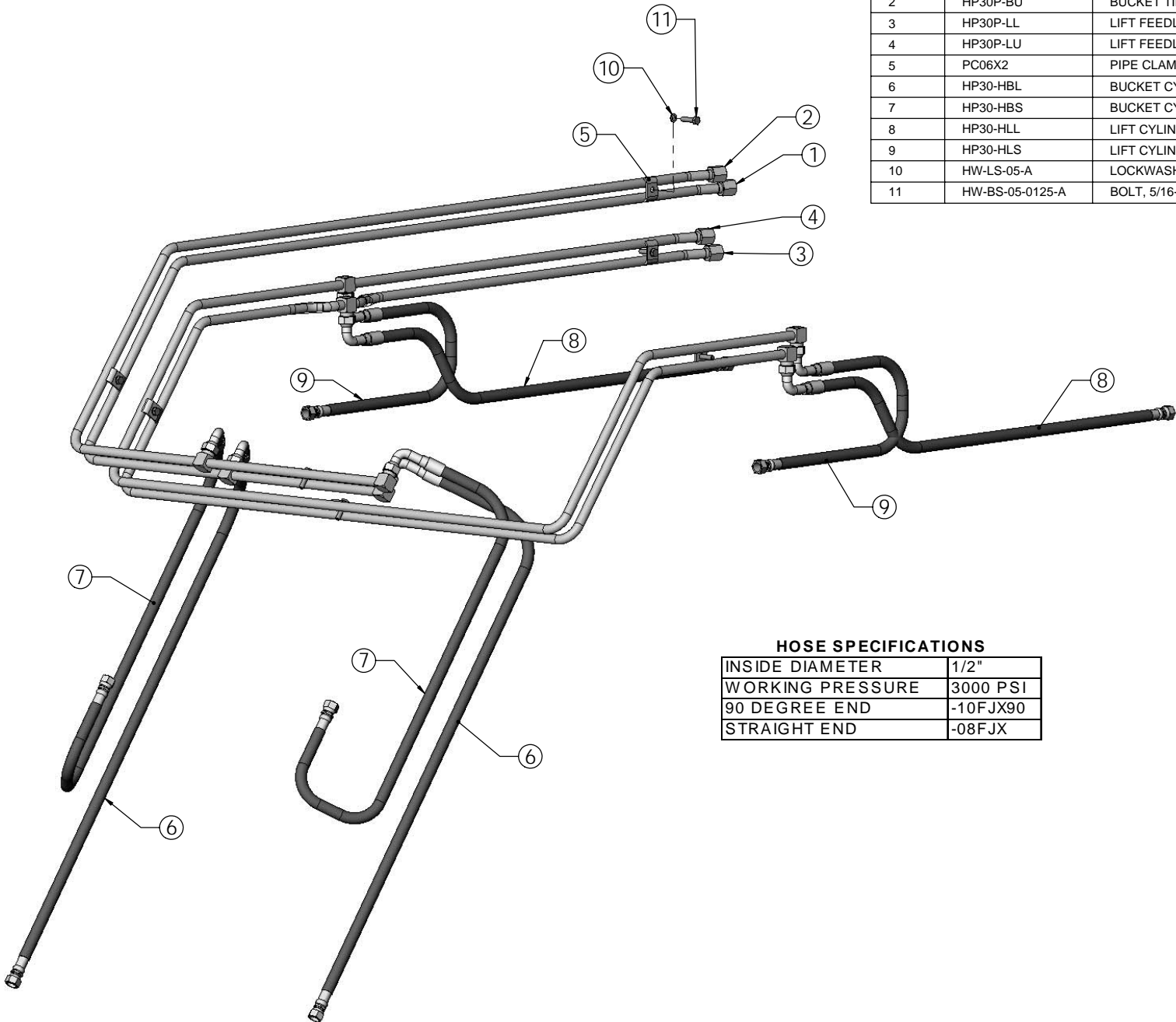

ITEM NO.	PART NUMBER	DESCRIPTION	with pipes/QTY.
1	HP30P-BL	BUCKET TILT FEEDLINE, LOWER	1
2	HP30P-BU	BUCKET TILT FEEDLINE, UPPER	1
3	HP30P-LL	LIFT FEEDLINE, LOWER	1
4	HP30P-LU	LIFT FEEDLINE, UPPER	1
5	PC06X2	PIPE CLAMP	7
6	HP30-HBL	BUCKET CYLINDER HOSE, LONG (45.5")	2
7	HP30-HBS	BUCKET CYLINDER HOSE, SHORT (41")	2
8	HP30-HLL	LIFT CYLINDER HOSE, LONG (35")	2
9	HP30-HLS	LIFT CYLINDER HOSE, SHORT (24")	2
10	HW-LS-05-A	LOCKWASHER, 5/16, ZN	7
11	HW-BS-05-0125-A	BOLT, 5/16-18 UNC, GR5 ZN, 1-1/4" LONG	7

HOSE SPECIFICATIONS

INSIDE DIAMETER	1/2"
WORKING PRESSURE	3000 PSI
90 DEGREE END	-10FJX90
STRAIGHT END	-08FJX

better built

MILLER

farm loaders

SCHEMATIC

GL30/GP30

HOSES & PIPING

DWG. NO. **HP30**

REV. **A**

WEIGHT: 23.706

DATE 1/13/2005

SHEET 1 OF 1

ITEM NO.	PART NUMBER	DESCRIPTION	with aux kit/QTY.
24	HP30P-GU	AUXILLARY FEEDLINE, UPPER	1
25	HP30P-GL	AUXILLARY FEEDLINE, LOWER	1
26	SF-2706-LN-10-08	BULKHEAD CONNECTOR, -10 JIC to 1/2 NPT	2
27	PC06X2	PIPE CLAMP	9
28	HW-BS-05-0100-A	BOLT, 5/16-18 UNC, GR5 ZN, 1" LONG	9
29	HW-LS-05-A	LOCKWASHER, 5/16, ZN	9
30	HOSE	SPECIFY LENGTH REQUIRED	2
31	HA-TP-4050-3	TIP, FEMALE 3/8 NPT (PIONEER 4050-3)	1
32	HA-TP-4010-3	TIP, MALE 3/8 NPT (PIONEER 4010-3)	1
33	SF-5405-06-08	EXPANDING PIPE ADAPTER, 3/8 to 1/2 NPT	2

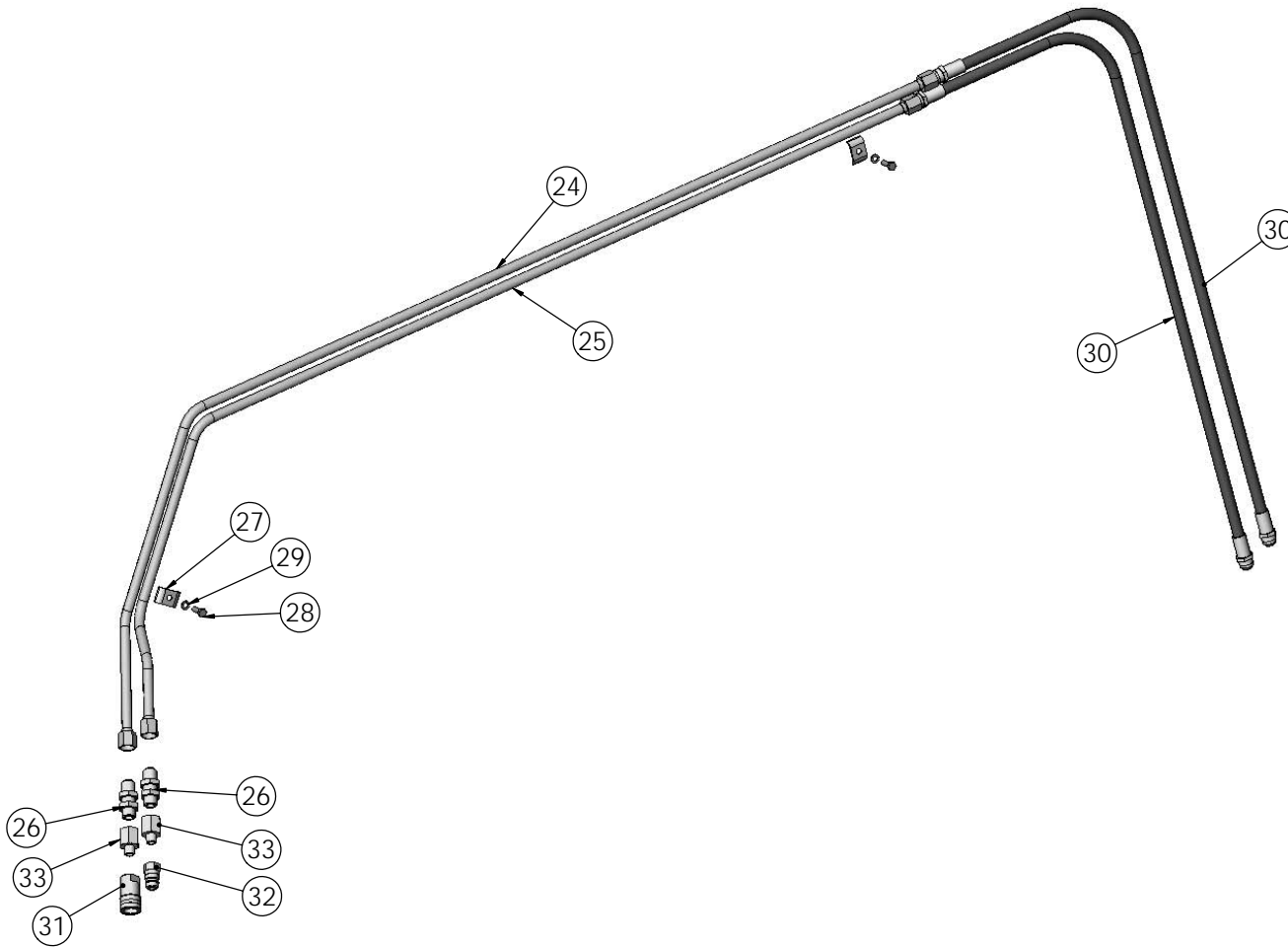



MILLER SCHEMATIC
 farm loaders

GL/GP30 LOADER
 AUX. LINE KIT

DWG. NO. AU30	REV. A
WEIGHT: 9.0	DATE 1/13/2005
SHEET 1 OF 1	

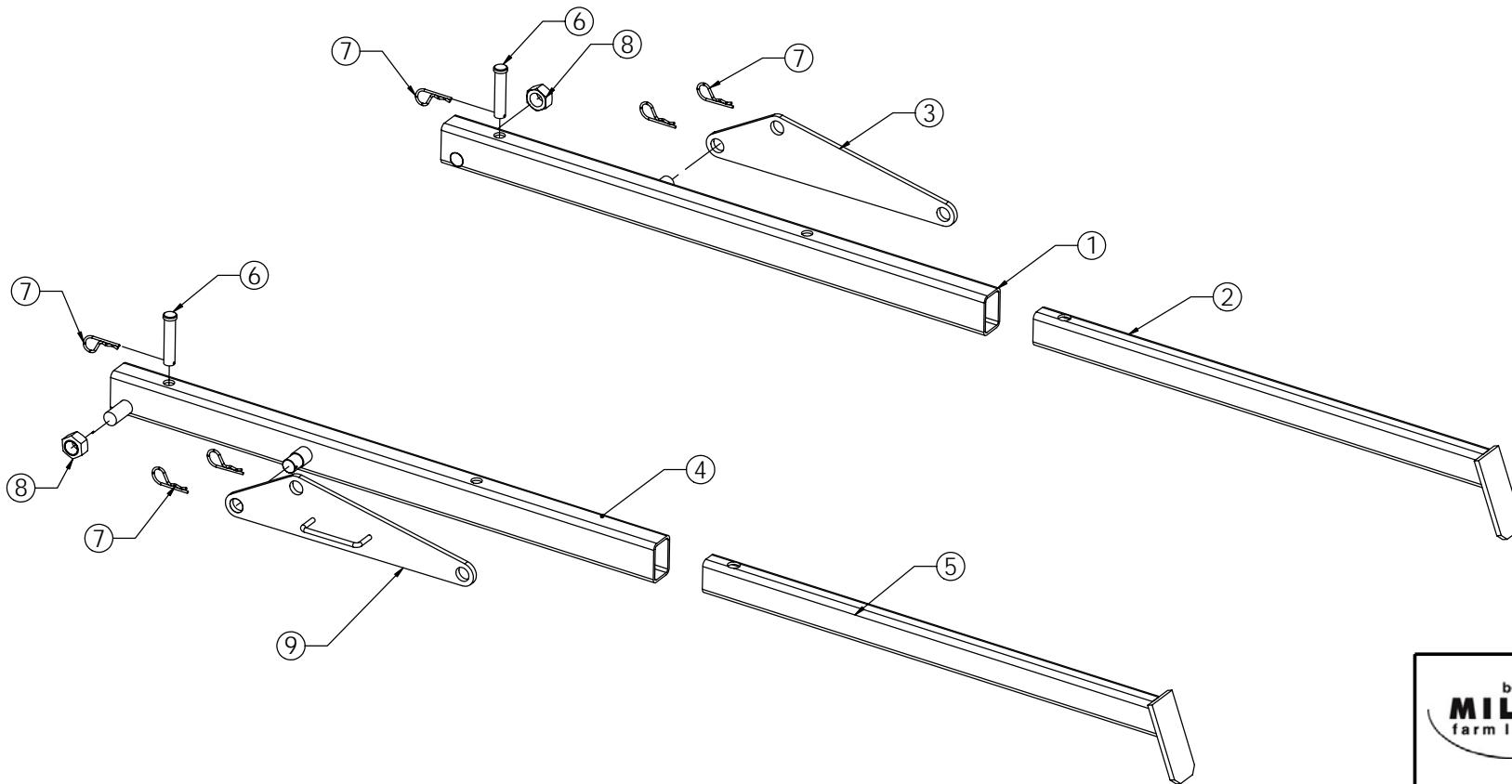
ITEM NO.	PART NUMBER	DESCRIPTION	Stand Legs/QTY.
1	SL30-TL	TOP TUBE ASSY, LEFT	1
2	SL30-BL	BOTTOM TUBE ASSY, STAND LEG (LH)	1
3	SL30-HL	STAND LEG HANDLE, LEFT	1
4	SL30-TR	TOP TUBE ASSY, RIGHT	1
5	SL30-BR	BOTTOM TUBE ASSY, STAND LEG (RH)	1
6	PIN1-006	CLEVIS PIN, 3/4 X 3 1/2 ZNC	2
7	PIN1-017	HAIRPIN COTTER, 2-11/16 LONG	6
8	HW-NS-16-E	NUT, 1-14 UNF GR8 TL, ZN	2
9	SL30-HR	STAND LEG HANDLE, RIGHT	1





MILLER SCHEMATIC
 farm loaders

GL30/GP30 LOADER
 STAND LEG PART LIST

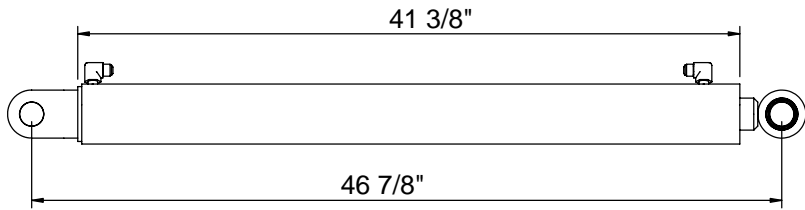
DWG. NO. SL30H	REV. A
WEIGHT: 85.345	DATE 1/13/2005
SHEET 1 OF 1	

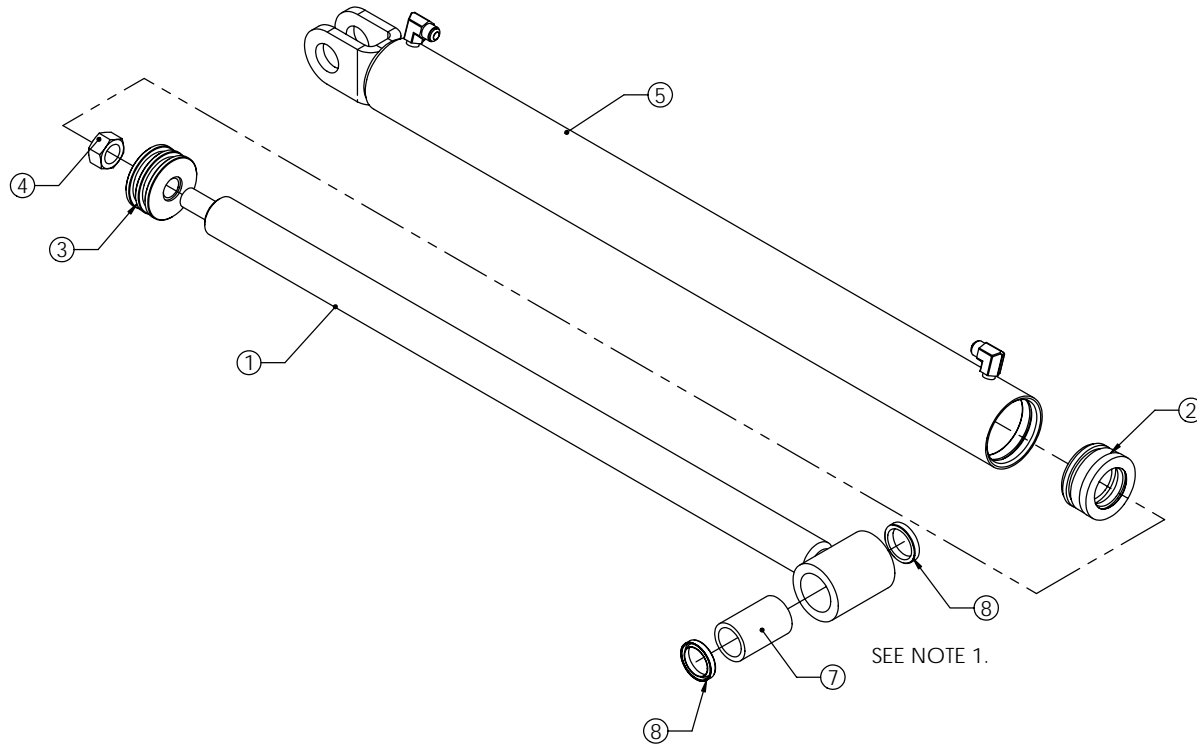

ITEM NO.	PART NUMBER	DESCRIPTION	QTY.
1	CY-058D	ROD ASSEMBLY, GL/GP30 LIFT	1
2	CP-GL-3220-L	GLAND, 3220 LONG-TAIL	1
3	CP-PS-3220-U	PISTON, 3220 U-CUP	1
4	HW-NS-16-A	NUT, 1-14 UNF, TOP LOCK, PLAIN	1
5	CY-058-LT	TUBE ASSEMBLY, GL30 LIFT, LH	1
6	CP-KT-3220-U	P-KIT, 3.250 X 2.000 UC	1
7	BR-2000K-3125	COMPOSITE BEARING, 1.50 BORE, 3.125 LONG	1
8	PS-1500-45	Pin Seal (MRW), 1.50 ID x 2.0 OD x 5/16 Thick	2



CY-058-L
 LIFT CYLINDER, GL30, LH

NOTES:
 1. BEARING AND SEALS SOLD SEPARATELY FROM COMPLETE CYLINDER.
 2. PACKING KIT SHOWN IN PART LIST, BUT NOT SHOWN IN DRAWING.

ALL DIMENSIONS IN INCHES

BORE ϕ	3.250
ROD ϕ	2.000
STROKE	36-1/2"
PORT STYLE	-08 JIC
WEIGHT:	82.681 LBS.

SCHEMATIC

LIFT CYLINDER, GL30, LH

DWG. NO. **CY-058-L**

DATE 1/28/2005 SHEET 1 OF 1

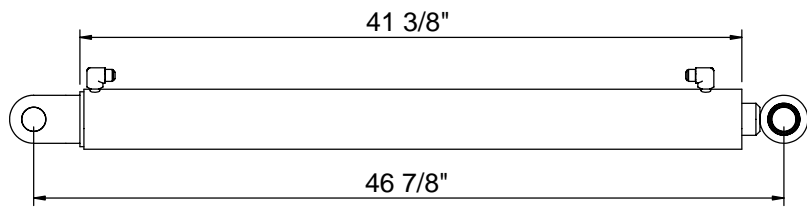

ITEM NO.	PART NUMBER	DESCRIPTION	QTY.
1	CY-058-RT	TUBE ASSEMBLY, GL30 LIFT, RH	1
2	CY-058D	ROD ASSEMBLY, GL/GP30 LIFT	1
3	CP-GL-3220-L	GLAND, 3220 LONG-TAIL	1
4	CP-PS-3220-U	PISTON, 3220 U-CUP	1
5	HW-NS-16-A	NUT, 1-14 UNF, TOP LOCK, PLAIN	1
6	CP-KT-3220-U	P-KIT, 3.250 X 2.000 UC	1
7	BR-2000K-3125	COMPOSITE BEARING, 1.50 BORE, 3.125 LONG	1
8	PS-1500-45	Pin Seal (MRW), 1.50 ID x 2.0 OD x 5/16 Thick	2

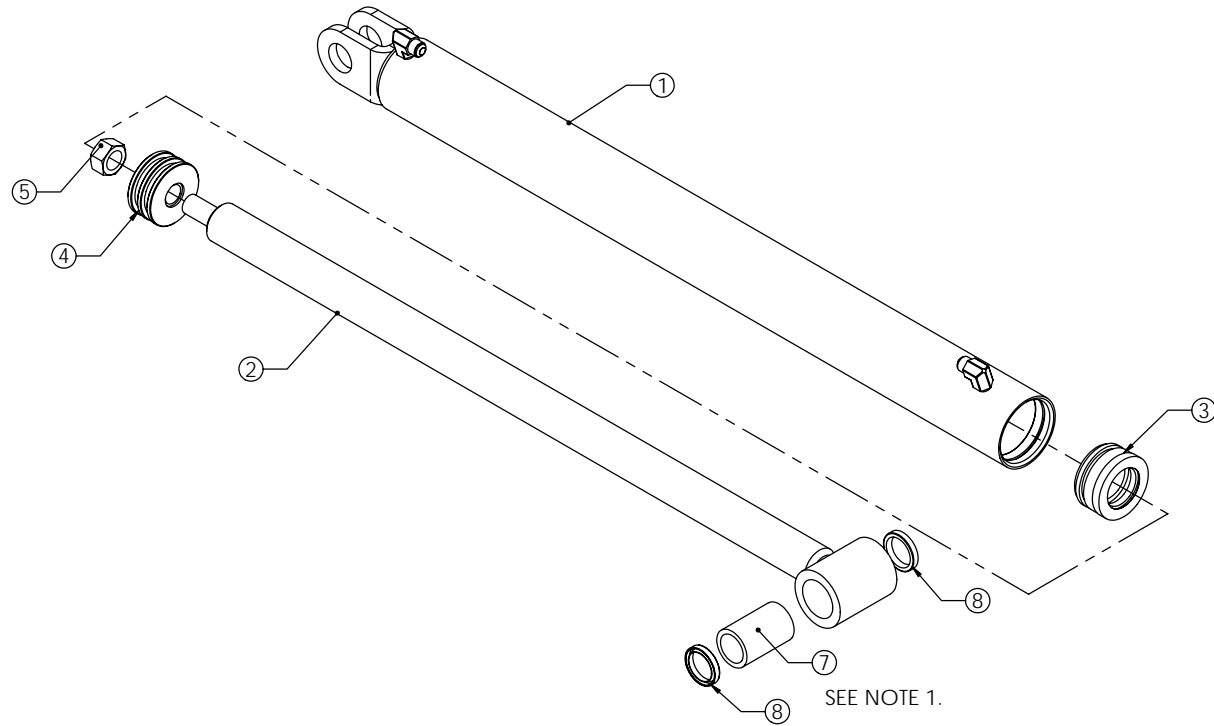

SEE NOTE 1.

CY-058-R
LIFT CYLINDER, GL30, RH

NOTES:
1. BEARING AND SEALS SOLD SEPARATELY FROM COMPLETE CYLINDER.
2. PACKING KIT SHOWN IN PART LIST, BUT NOT SHOWN IN DRAWING.

ALL DIMENSIONS IN INCHES

BORE ϕ	3.250
ROD ϕ	2.000
STROKE	36-1/2"
PORT STYLE	-08 JIC
WEIGHT:	82.681 LBS.

better built
MILLER
farm loaders

SCHEMATIC

LIFT CYLINDER, GL30, RH

DWG. NO. **CY-058-R**

DATE 1/28/2005

SHEET 1 OF 1

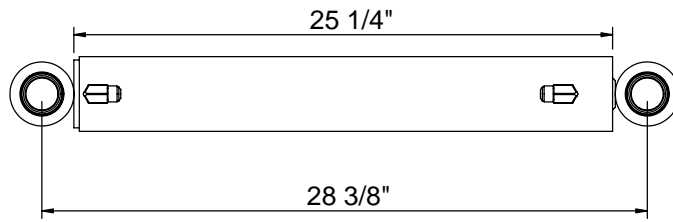

ITEM NO.	PART NUMBER	DESCRIPTION	QTY.
1	CY-059T	TUBE ASSEMBLY, GP/GL25-30 BUCKET	1
2	CY-059D	ROD ASSY, GL/GP30 BUCKET	1
3	CP-GL-3017-S	GLAND, 3017, SHORT-TAIL	1
4	CP-PS-3017-U	PISTON, 3017 U-CUP	1
5	HW-NS-16-A	NUT, 1-14 UNF, TOP LOCK, PLAIN	1
6	CP-KT-3017-U	P-KIT, 3.000 X 1.750 UC	1
7	PS-1500-45	Pin Seal (MRW), 1.50 ID x 2.0 OD x 5/16 Thick	4
8	BR-2000K-3750	COMPOSITE BEARING, 1.50 BORE, 3.75 LONG	1
9	BR-2000K-3125	COMPOSITE BEARING, 1.50 BORE, 3.125 LONG	1

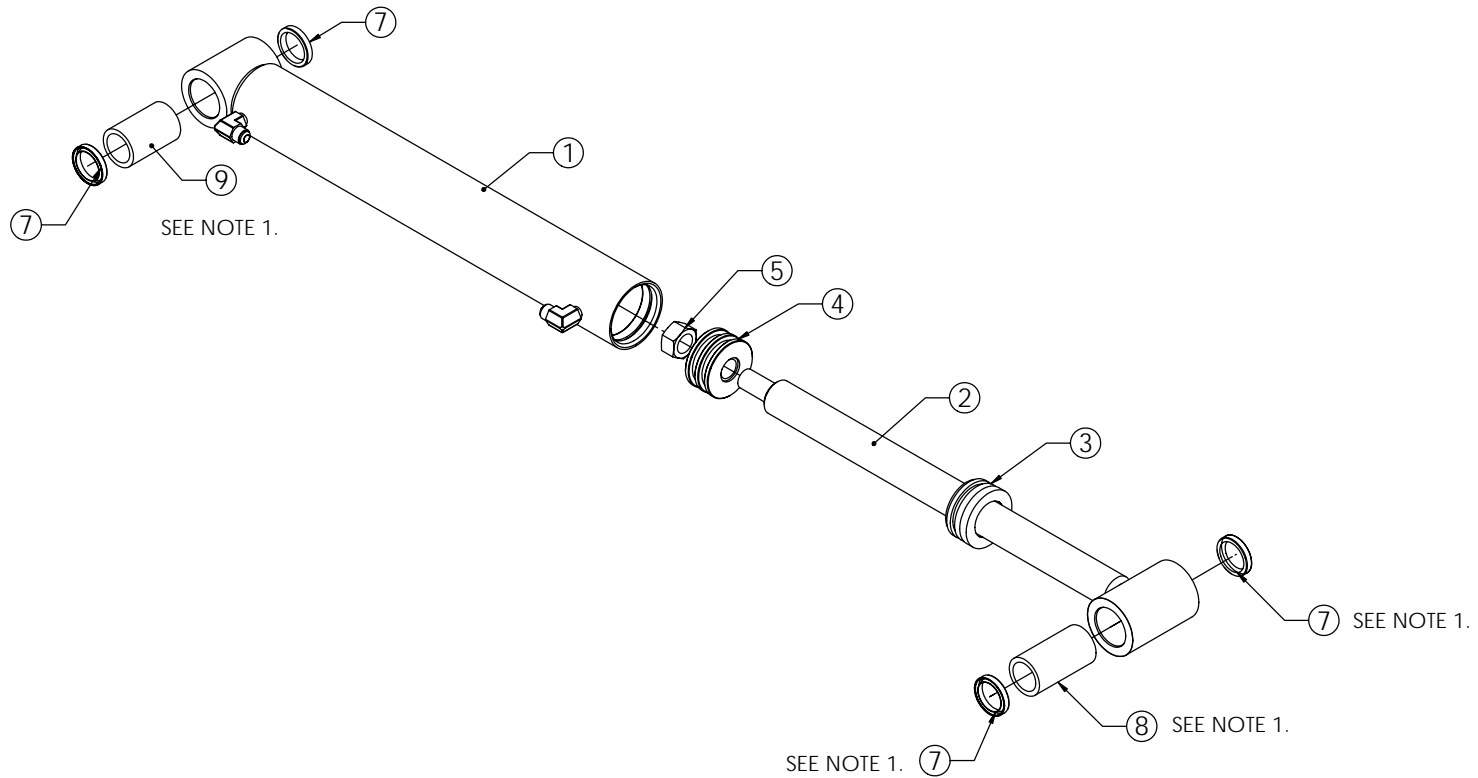

NOTES:
 1. BEARINGS AND SEALS ARE SOLD SEPARATELY.
 2. PACKING KIT SHOWN IN PART LIST, BUT NOT SHOWN IN DRAWING.

CY-059
 CYLINDER, GL/GP30 BUCKET

ALL DIMENSIONS IN INCHES

BORE ϕ	3.000
ROD ϕ	1.750
STROKE	20-5/8"
PORT STYLE	-08 JIC
WEIGHT:	49.822 LBS.

SCHEMATIC
 CYLINDER, GL/GP30 BUCKET
 DWG. NO. **CY-059**
 DATE 1/28/2005 SHEET 1 OF 1

SEAL, U-CUP, LARGE

O-RING, LARGE

B/U WASHER

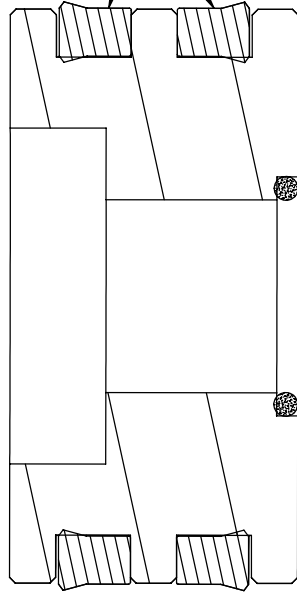

O-RING, SMALL

PISTON

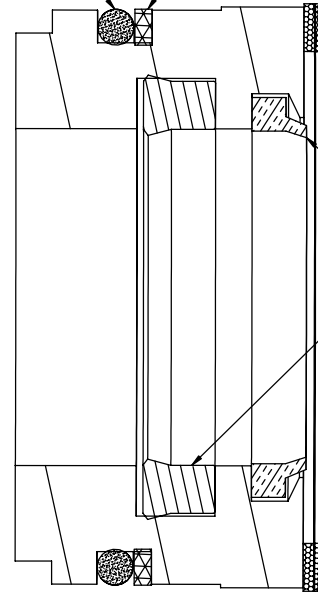

ROD WIPER

SEAL, U-CUP, SMALL

SNAP RING

GLAND

FRONT OF CYLINDER



 MILLER farm loaders		SCHEMATIC	
PACKING CONFIGURATION, U-CUP			
DWG. NO. CP-KT-U		REV. A	
WEIGHT:	DATE 1/13/2005	SHEET 1 OF 1	

GL30 SPECIFICATIONS

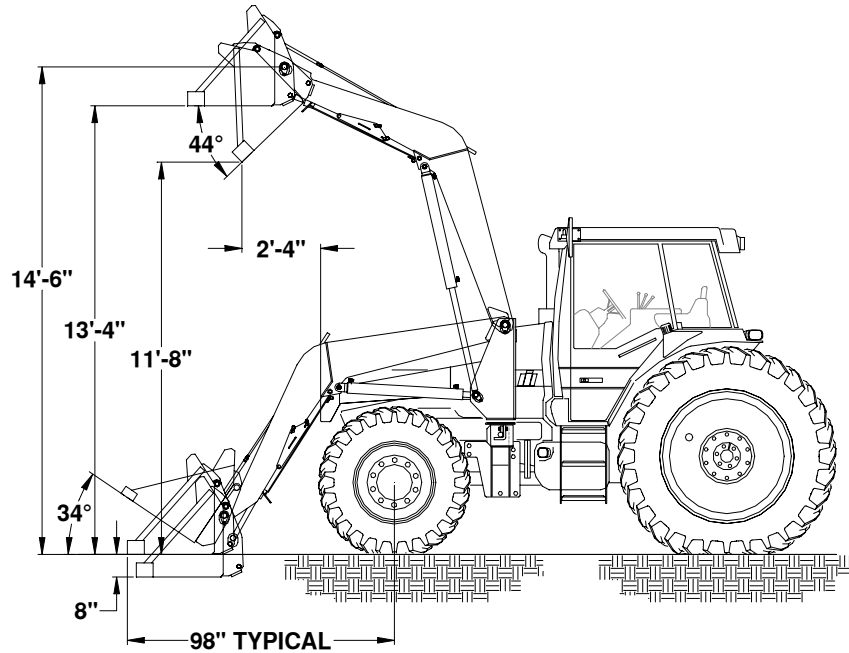

SPECIFICATIONS AND PERFORMANCE NUMBERS ARE FOR REFERENCE ONLY

LIFTING CAPACITY:

Breakaway Lift	: 7600 lbs.
Full Height Lift	: 5400 lbs.

With load 800mm (31.5") ahead of bucket pivot
And 2850 psi pressure at lift cylinders

WEIGHTS:

Loader (less bucket and mounts)	: 2500 lbs.
8 FT Bucket	: 800 lbs.
Mounting Kit (Typical)	: 550 lbs.
Total	: 3850 lbs.



WARRANTY

Dec 2004

ALL PRODUCTS MANUFACTURED BY MILLER LOADERS, INCORPORATED (**MLI**) EXCEPT THE CHROME-PLATED PIVOT PINS USED ON GREASELESS LOADERS, ARE GUARENTEED TO THE ORIGINAL PURCHASER FOR A PERIOD OF ONE YEAR FROM THE DAY OF PURCHASE AGAINST ANY DEFECTS IN MATERIALS AND WORKMANSHIP OF FARM LOADERS AND ATTACHMENTS THAT ARE USED IN NORMAL FARM OPERATIONS. THE CHROME-PLATED PIVOT PINS USED ON GREASELESS LOADERS ARE GUARENTEED TO THE ORIGINAL PURCHASER FOR A PERIOD OF FIVE YEARS FROM THE DAY OF PURCHASE AGAINST ANY DEFECTS IN MATERIALS AND WORKMANSHIP OR AGAINST WEAR THROUGH OF THE CHROME FINISH COVERING AT LEAST ONE-QUARTER OF THE PIN SURFACE.

ALL GREASELESS COMPOSITE BEARINGS SOLD BUT NOT MANUFACTURED BY **MLI** ARE GUARENTEED TO THE ORIGINAL PURCHASER FOR A PERIOD OF FIVE YEARS FROM THE DAY OF PURCHASE AGAINST BREAKAGE OR LOSS OF THEIR SELF-LUBRICATING PROPERTY.

THE FIVE YEAR WARRANTY FOR THE CHROME-PLATED PIVOT PINS AND GREASELESS COMPOSITE BEARINGS IS LIMITED TO THE PARTS ONLY. **MLI** IS NOT RESPONSIBLE FOR ANY LABOR NECESSARY FOR THE INSPECTION, REMOVAL, OR REPLACEMENT OF SAID PIVOT PINS AND/OR COMPOSITE BEARINGS.

ALL PARTS SOLD BUT NOT MANUFACTURED BY **MLI** THAT INCLUDE BUT ARE NOT LIMITED TO ZINC-PLATED PINS, HOSES, VALVES, QUICK COUPLERS, PUMPS, TANKS, ETC. ARE COVERED ONLY TO THE EXTENT OF THE MANUFACTURE'S WARRANTY ON THESE ITEMS. **MLI** DOES NOT WARRANTY THESE ITEMS EXPRESSLY OR IMPLIEDLY.

DEFACEMENT OF ANY PART BY WELDING OR OTHERWISE ALTERING, OR EXCESSIVE WEAR ON PINS CAUSED BY LACK OF LUBRICATION, NULLIFIES THE WARRANTY ON THE **MLI** PRODUCT.

MLI ASSUMES NO RESPONSIBILITY AS TO THE PERFORMANCE OR FAILURE OF A TRACTOR'S HYDRAULIC SYSTEM.

THE HYDRAULIC COMPONENTS OF THE **MLI** PRODUCTS ARE GUARENTEED UP TO A PRESSURE OF 3000 POUNDS PER SQUARE INCH AT A MAXIMUM FLOW RATE OF 30 GALLONS PER MINUTE.

MLI ASSUMES NO RESPONSIBILITY FOR THE FAILURE OF THE PURCHASER TO SECURE THE LOADER TO THE TRACTOR PROPER, WHICH INCLUDES PROPER BOLT TIGHTENING AND SECURING OF ALL CONNECTION POINTS.

ALL ITEMS MANUFACTURED BY **MLI** REQUIRING WARRANTY CONSIDERATION MUST BE RETURNED TO **MLI** OR A DESIGNATED REPRESENTATIVE BY THE ORIGINAL PURCHASER. ANY ITEM SO RETURNED BY COMMON CARRIER MUST BE PREPAID FREIGHT.

THE WARRANTIES PROVIDED BY **MLI** AS REFERRED TO ABOVE SHALL BE THE SOLE AND EXCLUSIVE WARRANTIES. THERE SHALL BE NO OTHER WARRANTIES EXPRESS OR IMPLIED INCLUDING ANY IMPLIED WARRANTY OF MERCHANTABILITY OR FITNESS OR ANY OTHER OBLIGATION ON THE PART OF **MLI** WITH RESPECT TO PRODUCTS COVERED BY THIS WARRANTY.

IN NO EVENT SHALL THE WARRANTIES OF **MLI** REQUIRE MORE FROM **MLI** THAN THE REPAIR OR REPLACEMENT OF ANY PART OR PARTS WHICH ARE FOUND TO BE DEFECTIVE WITHIN THE EFFECTIVE PERIOD OF THE WARRANTY, **MLI** SHALL HAVE NO LIABILITY FOR ANY INCIDENTAL OR CONSEQUENTIAL DAMAGES.

MILLER LOADERS INC, 1242 ARIZONA AVE, LARCHWOOD, IA 51241

PHONE: 1-800-570-8205
Or (712) 477-2795

FAX: (712) 477-2500